

Mounting Adapter for Linear Actuator Ball Screw Type

Assemble it to a stepping motor to achieve linear motion

- Adopting Rolled Ball Screws
- Repetitive Positioning Accuracy ± 0.01 mm
- Maximum Thrust 160N

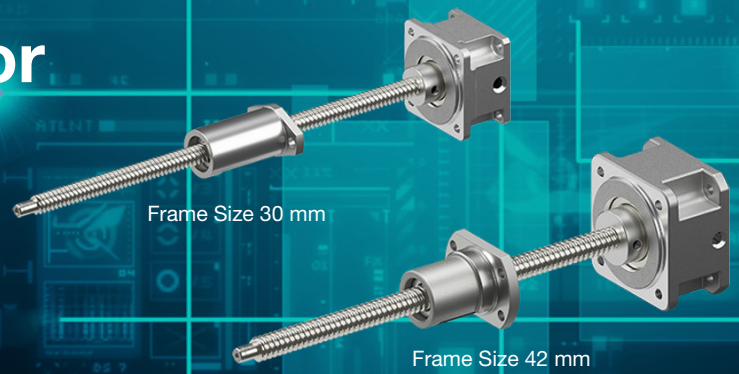

Mounting Adapter using Rolled Ball Screws

The LA attachment Rolled Ball Screw type is a mounting adapter for combination with Oriental Motor stepping motors.

They consist of a rolled ball screw and a nut, and can be easily assembled without couplings, reducing the number of parts and assembly work compared to custom-made mechanisms.

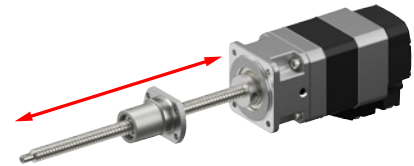

Specifications

Product Name	Frame Size [mm]	Lead [mm]	Stroke [mm]	Permissible Thrust [N]	Permissible Speed [mm/s]	Transportable Mass [kg]		Repetitive Positioning Accuracy [mm]
						Horizontal	Vertical	
LA303A10	30	3	100	50	120	5	5	± 0.01
LA306A10		6		25	240		2.5	
LA422A10Z	42	2		160	60	16	16	
LA428A10Z		8		40	240		4	

Operating Speed with Frame Size 30 mm and 42 mm - Allowable Thrust

Compact but with high thrust and high speed. Contributes to reduced equipment cycle time.

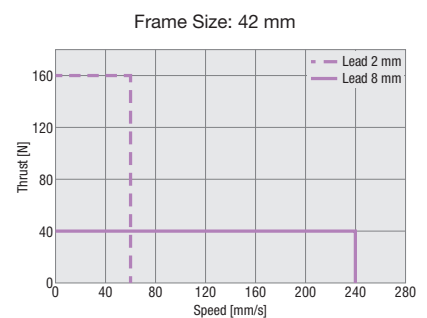
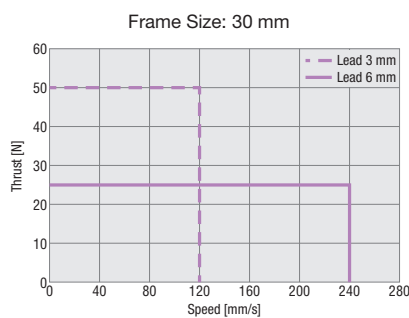
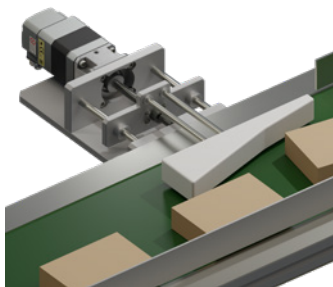

Compact Design Allows for Quicker Equipment Development

By using a mounting adapter for linear actuators, space is saved due to the reduced number of parts. The amount of time required for installation and accuracy adjustment can also be reduced. This allows for equipment startup in a shorter time.

- Custom-built
(Number of components: 9)

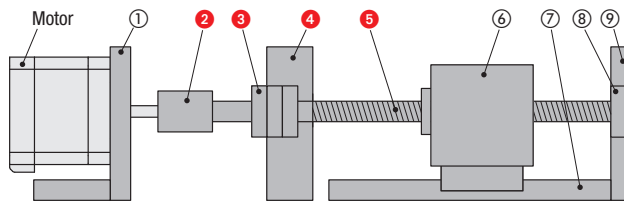

①	Installation Plate
②	Coupling
③	Fixed-Side Bearing
④	Fixed-Side Block
⑤	Leadscrew
⑥	Transport Table
⑦	Linear Guide
⑧	Support-Side Bearing
⑨	Support-Side Block

Parts Reduction

- When using mounting adapter for linear actuator
(Number of components: 6)

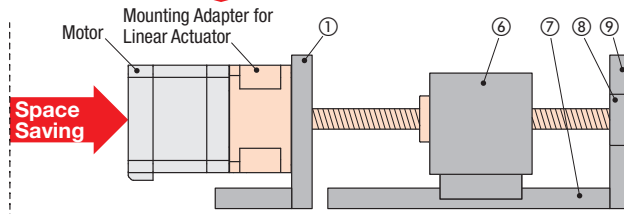

Axial Load Can Be Applied Directly

The axial bearing mechanism is used to directly support axial loads.

Axial Bearing Mechanism Adopted



Application Examples

By reducing the number of parts such as the coupling that connects the motor and screw, the equipment space can be saved. Positioning transport at speeds of up to 240 mm/s is possible.

- Elevating and Lowering Axis of the Parts Feed



- Centering of the Substrate Transportation

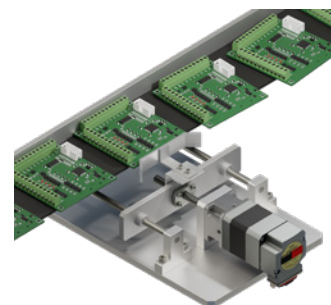

Wide Variety of Motors and Drivers to Provide More Reliable Motion

Linear actuators can be combined with the **AZ** Series to perform high-precision origin return without using external sensors. Furthermore, they are compatible with major fieldbus networks, contributing to centralised device information management and reduced wiring.

Ball Screw
Mounting Adapter for Linear Actuators

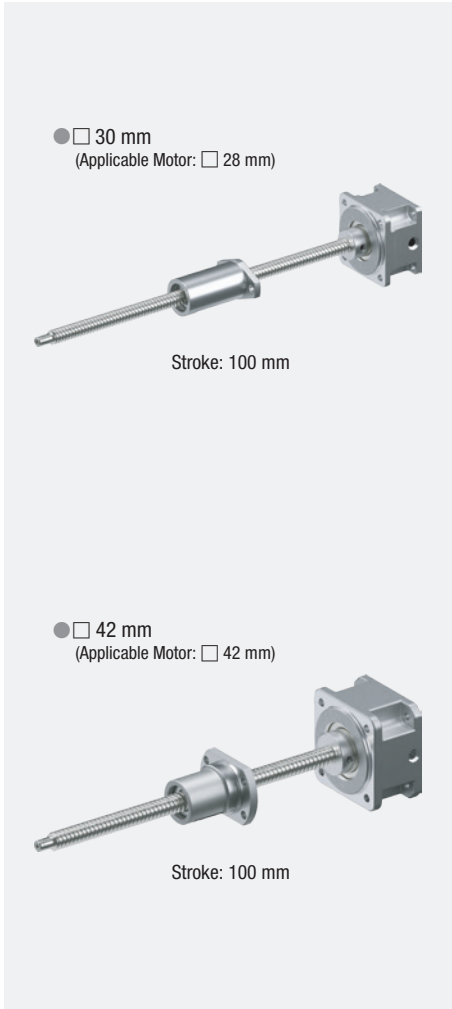

Battery-less Absolute Sensor
QSTEPAZ Series Motor
(□ 28 mm, □ 42 mm*¹)

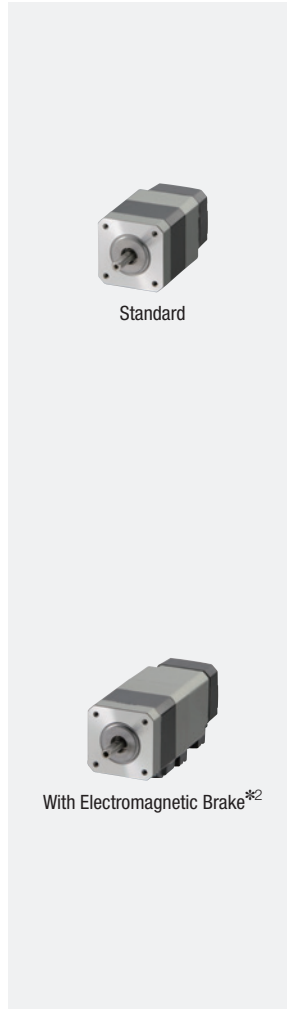

Fieldbus compatible
QSTEPAZ Series Driver
DC Power Input



*1 **AZM46** only.

*2 Only available for 42 mm frame size.

■ Combination with battery-less absolute sensor motor

- Return to origin possible without origin sensor or limit sensor
- Compatible with common fieldbus protocols

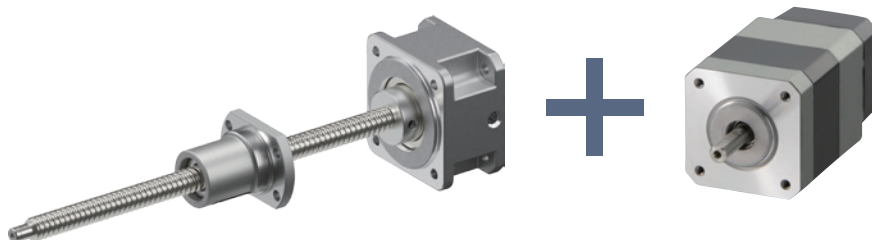

Product Code

LA 42 2 A 10 Z

① ② ③ ④ ⑤ ⑥

①	Name	LA Attachment
②	Frame Size	30 : 30 mm 42 : 42 mm
③	Lead	2 : 2 mm 3 : 3 mm 6 : 6 mm 8 : 8 mm
④	Driving Screw Type	A : Ball Screw
⑤	Stroke	10 : 100 mm
⑥	Applicable Motor	Blank: <i>αSTEP AZ</i> Series Frame Size 28 mm Z : <i>αSTEP AZ</i> Series Frame Size 42 mm*

*AZM46 only.

Product Line

Frame Size [mm]	Product Name	Applicable Motors
30	LA303A10	<i>αSTEP AZ</i> Series Frame Size 28 mm
	LA306A10	
42	LA422A10Z	<i>αSTEP AZ</i> Series Frame Size 42 mm*
	LA428A10Z	

*AZM46 only.

Orientalmotor

Oriental Motor (Europa) GmbH

European Headquarters
Schiessstraße 44
40549 Düsseldorf, Germany
Tel: +49 211 520 670 0
contact@orientalmotor.de
www.orientalmotor.eu



These products are manufactured at plants certified with the international standards **ISO 9001** (for quality assurance) and **ISO 14001** for systems of environmental management). Specifications are subject to change without notice. This catalogue was published in August 2025. Printed in Germany.

© Copyright Oriental Motor (Europa) GmbH 2025
UK/082025/VERS01