

Procedure for Introducing Custom-Built Robots

- The Advantages of Custom-Built Robots
- Case Study of a Custom-Built Robot
- From Considering Automation to Robot Assembly
- The Features of the Robot Controller

MRC01

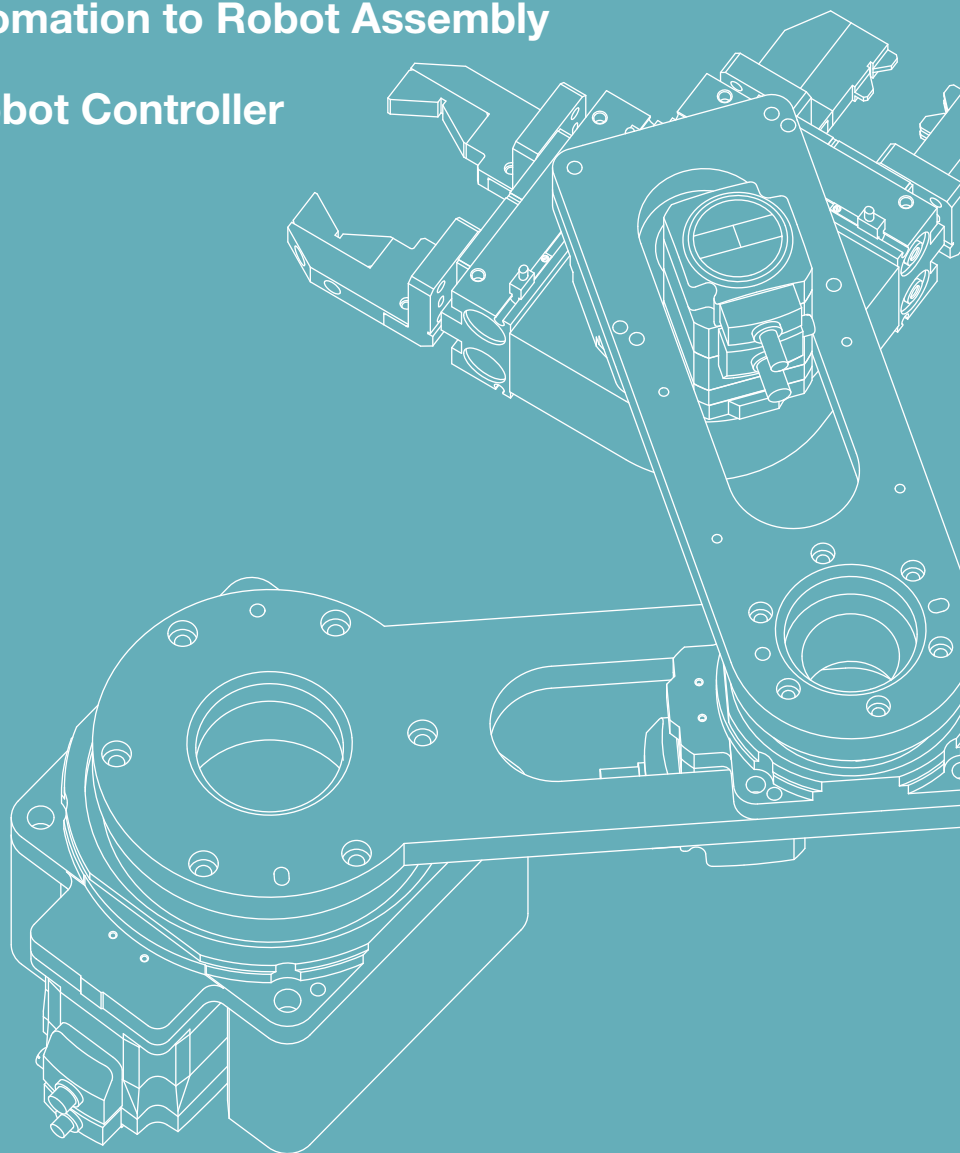



Contents

1. The Advantages of Custom-Built Robots

P3

This section discusses the advantages of custom-built robots.

2. Case Study of a Custom-Built Robot for Oriental Motor Production Equipment

P5

This section discusses a custom-built robot that has been adopted into Oriental Motor equipment.

3. From Considering Automation to Robot Assembly

P7

This section discusses the procedures required for in-house production.

- Confirmation of the movements to be achieved
- Determination of the robot type
- Robot arm design
- Select motor
- Preparation of parts
- Assembly procedure
- Setup
- Operation check

4. The Features of MRC01

P15

This section discusses the robot controller **MRC01**, which simplifies multi-axis robot control.

1

The Advantages of Custom-Built Robots

Reduction of the Total Cost Associated with Introducing a Robot

The initial cost is not the only cost reduced when introducing a robot.

In-house production also reduces the maintenance costs after adoption. This decreases the total cost.

Deployment Costs

Robot deployment expenses

Maintenance Costs

Robot maintenance contract expenses (Increase each time the contract is renewed)

Maintenance part purchase expenses

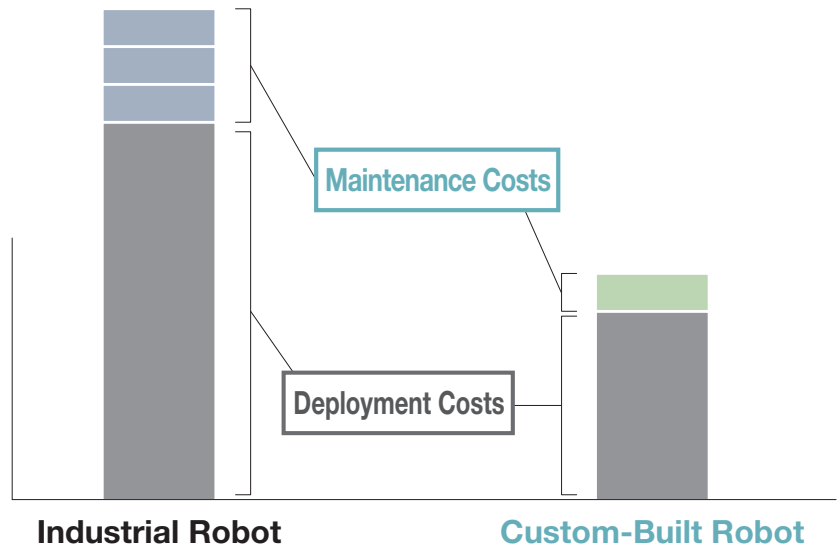

● Case study of Oriental Motor equipment

Shortened Time to Recover after Stoppage from Robot Malfunction

The cause of a malfunction can be identified and parts replaced in-house. Having maintenance parts on-hand minimizes the blow from a mass production equipment malfunction.

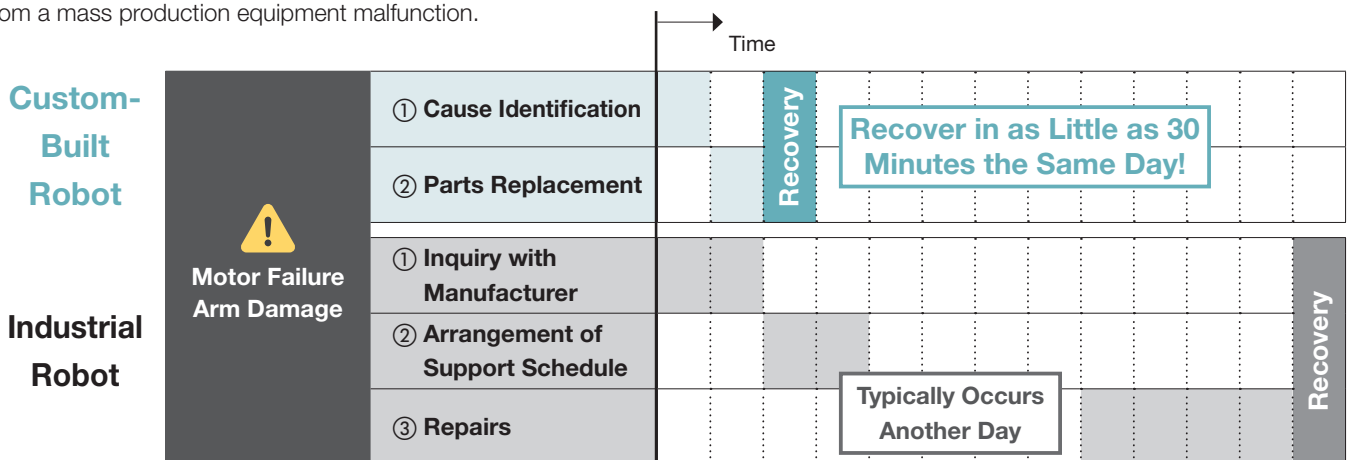

● Case study of Oriental Motor equipment

Maintenance Can Be Handled In-House After Adoption

Cost Reduction and Space Saving Through Maintenance at the Part Level

Custom-Built Robot

- Preparation of maintenance parts only
- Can be stored in shelves



Industrial Robot

- Maintenance robot is required (separate from operating unit)
- Storage space must be secured



Even if multiple robots are introduced, the common parts can be maintained altogether

Maintenance-free with the AZ Series

With industrial robots, regular maintenance is recommended.

(Batteries are replaced about once a year.)



Have these situations ever happened?

- Management became dependent upon individual efforts and years passed without anything being done
- Planning for maintenance is troublesome
- Location information was lost due to battery replacement

*α*STEP AZ Series

- The battery-free sensor eliminates the need for battery replacement
- Big product line of products that don't require greasing

Battery-Free
Built-in Multi-Turn
Absolute Sensor

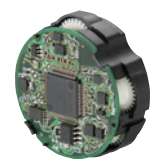

ABZO Sensor

2

Case Study of a Custom-Built Robot for In-House Production Equipment

Four horizontally articulated robots were introduced in the assembly process of motor parts. Production capacity more than doubled thanks to the activation of human resources.

Before



Load removal and attachment by hand while moving between equipment

After



Automated with robots

The line configuration was reviewed at the same time

Example of Automation

Removing and attaching loads from/to a jig

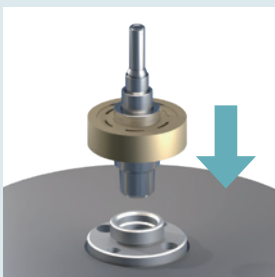

Gap between shaft and hole: 0.016 mm – 0.054 mm



Standardized design and horizontal development of the same units

Point 1: Existing Process Equipment Remains in Place

Load removal/attachment work automated

Introducing four horizontally articulated robots reduces the number of personnel in the rotor assembly process from two to zero.

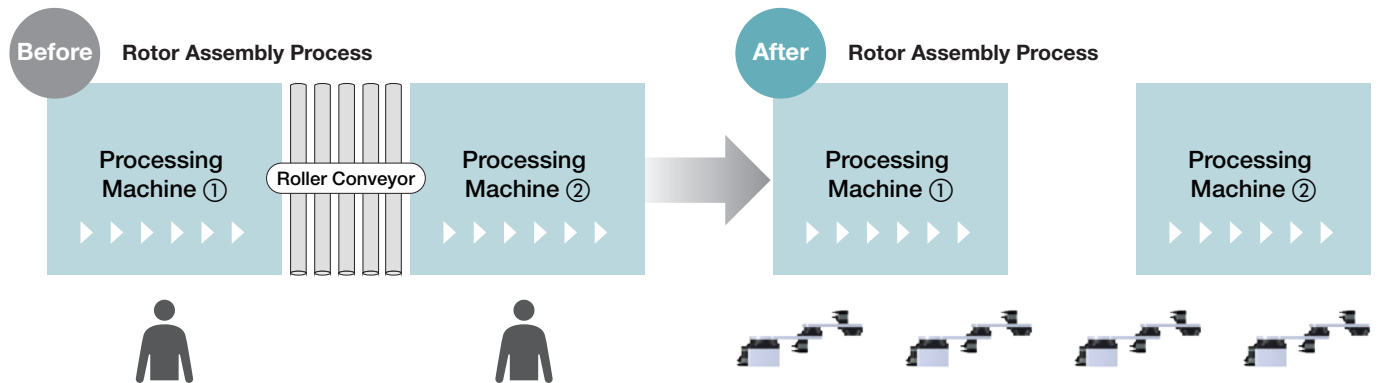

Point 2: Optimal Design for the Equipment

Height restrictions at the load entrance make it difficult to introduce industrial robots

The Z-axis is placed at the base, so the arm portion can be designed thinner and fit into narrow spaces.

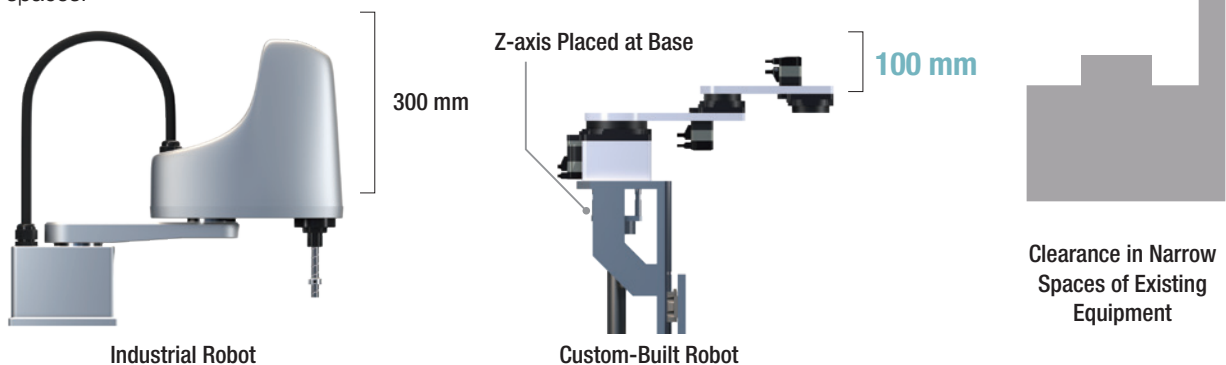

Point 3: Basic Design Can Be Repurposed

Arm length can be customized for each model according to equipment height and transport distance

Since the shape and number of axes are the same, selection calculations are completed only by changing the numerical values.

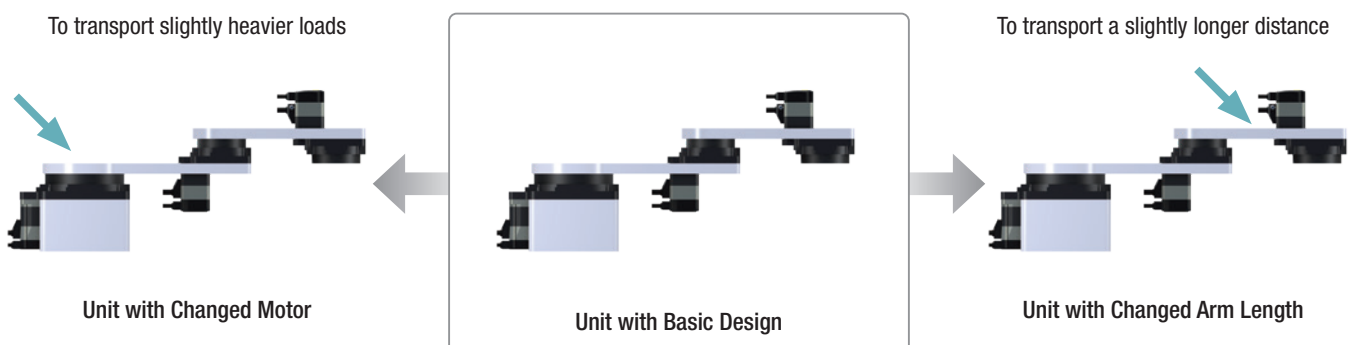



3

From Considering Automation to Robot Assembly

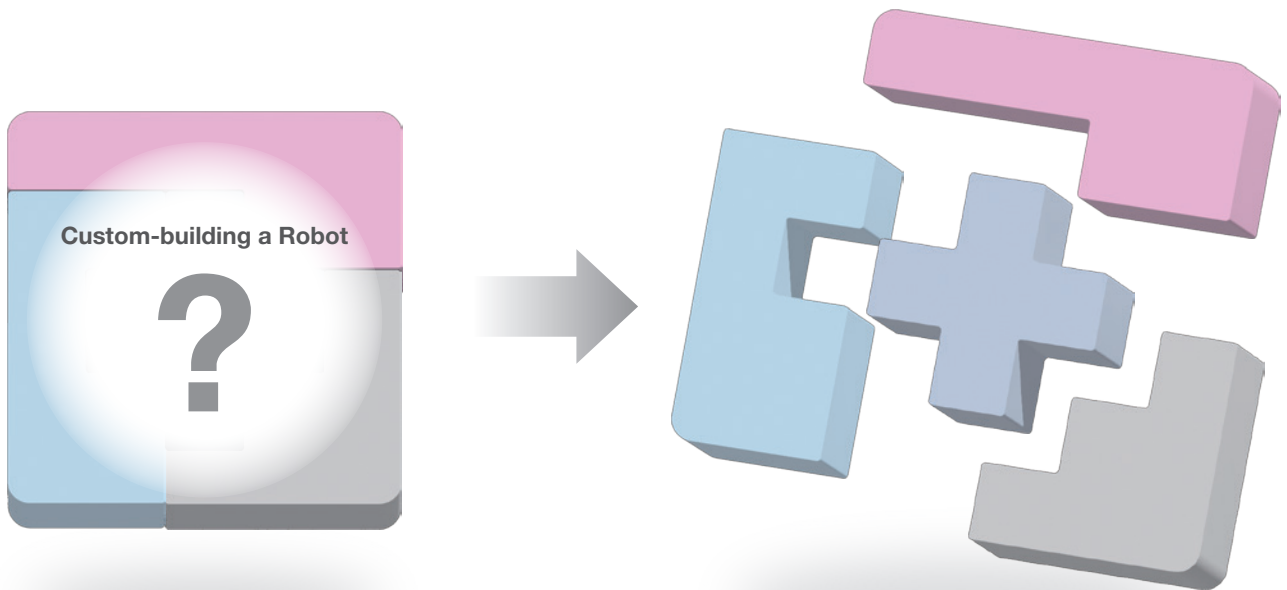
We will introduce the procedure for custom-building a robot that matches a desired movement, based on actual examples.

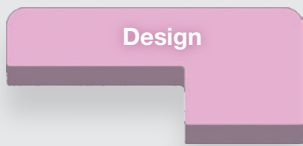

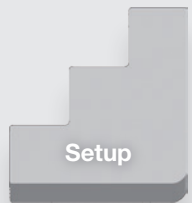
STEP 1	STEP 2	STEP 3	STEP 4
 Specification	 Design	 Assembly	 Setup
Determination of Robot Specifications <ul style="list-style-type: none">Confirmation of the movements to be achievedDetermination of the robot type	Robot Design <ul style="list-style-type: none">Robot arm designRobot arm design tipsSelect motor	Robot Assembly <ul style="list-style-type: none">Preparation of partsAssembly procedure	Setup <ul style="list-style-type: none">MRC01/MRC StudioOperation check

STEP 1

Determination of Robot Specifications

Confirmation of the Movements to be Achieved

Purpose of Introducing Robots

Automation of inter-process load transporting, reducing personnel.

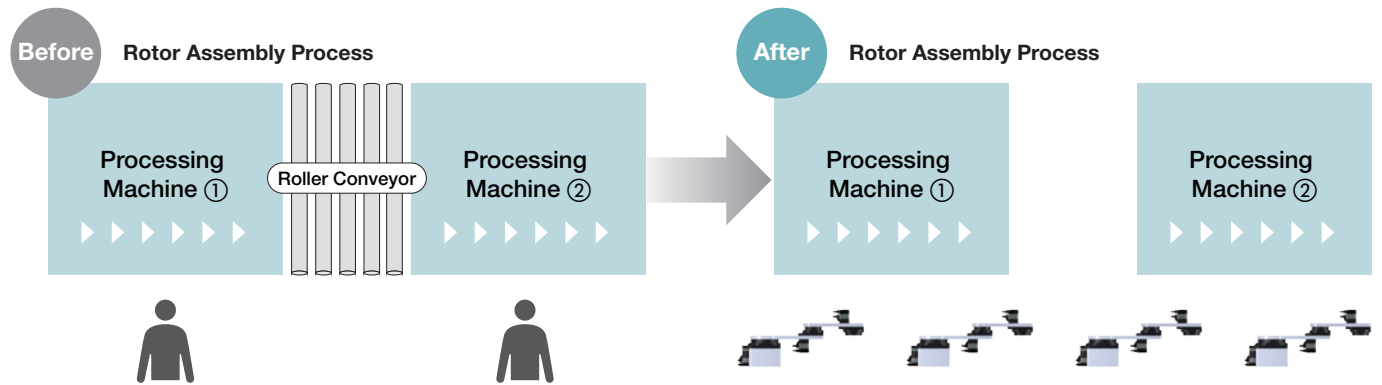

	Existing Line	Goal
Cycle Time	25 seconds/unit	25 seconds/unit
Workers on Line (Excluding catering)	2 workers	0 workers Personnel Reduced by Two

Specifications and Requirements for Custom-Built Robots

Required Movements

- 1 Load gripping
- 2 Carrying in and out
- 3 Removal/attachment by vertical movement

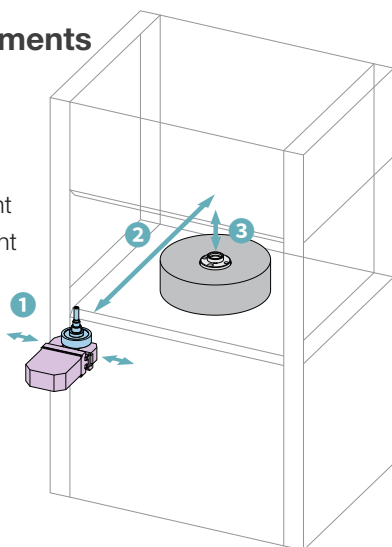

Movement Conditions

- Weight of load
Max. 500 g
- Required reach length
Max. 500 mm
- Traveling time
Work completed in the same or less than a person

Determination of the Robot Type

It is important to select the appropriate robot type, taking into account the required movements and any restrictions on the introduction of robots.

MRC01-Compatible Robot Types and Features

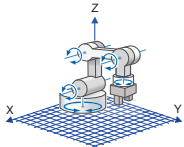
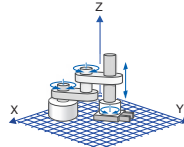
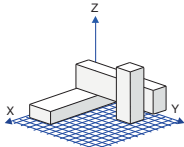
	Vertical Articulated Robot 	Horizontal Articulated Robot (SCARA Robot) 	Cartesian Robot 
Moving Range	Wide	Narrow Compared to a Cartesian robot, the moving range in the Y-axis direction is wider	Narrow
Installation Area	Narrow		Wide
Positioning Accuracy	Difficult to achieve accuracy		Easy to achieve accuracy
Rigidity	Low		High
Speed	Slow	Fast	Fast
Size of Loads that can be Handled	Small to large	Small	Small to large

Points to Consider when Determining the Robot Type

The reasons for introducing horizontally articulated robots for in-house equipment are summarized below.

Selection Requirement	Aim	Vertical Articulation Robot	Horizontal Articulated Robot	Cartesian Robot
Installation Area	Installation in limited space	○	○	
Moving Range	Height restriction at equipment entrance	○	○	○
Movements Required of Robot	Removal & attachment and transportation (no twisting motion required)	○ Over-performance	○	○

Robot Arm Design

Robot configuration: 3-axis horizontal articulated robot + elevating axis (base) + end effector

Role of Each Axis

Axes 1 & 2 (shoulder & elbow)

Arm position control

Axis 3 (wrist)

End effector angle control

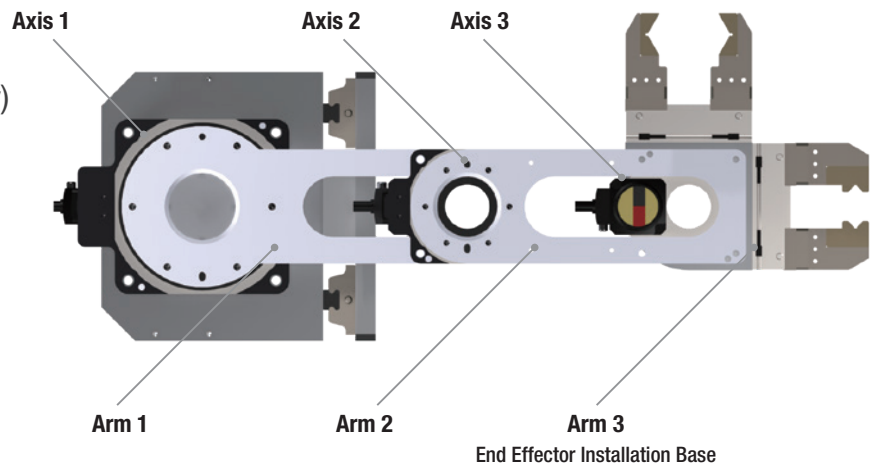

Point
1

Total Arm Length

Target is distance from robot installation point to target point + 10%

- Generous length design is required. If the arms are fully extended, the robot cannot be controlled.
- Excessive leeway increases the load on the motor and limits the transportation speed, etc.

Point
2

Ratio of Length of Each Arm

Arm 1:Arm 2:Arm 3 = 4:3:1 (estimate)

- If Arm 2 is too short relative to Arm 1, there will be a blind spot near the base of the robot.
- Arm 3 is used for end effector angle control. The length must be such that the end effector and Arm 2 do not interfere with each other in the desired angular range of rotation.

Use of the DGII Series Simplifies Arm Design

Installation type: **Surface mounting**

No couplings or other fastening parts needed.

Can be mounted by putting screw holes in the plate.



Robot Arm Design



Arm 1



Arm 2

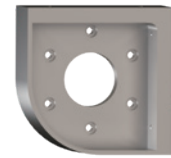

Arm 3
End Effector Installation Base

Design Points

- Aluminum alloy (A5052) is used to make the arms lighter
- Holes are also put in the arms for wiring using the hollow bore in the **DGII Series**

Robot Arm Design Tips

A Little Bit of Ingenuity Leads to a Wired Smart Robot

Lighter & Organized Wiring

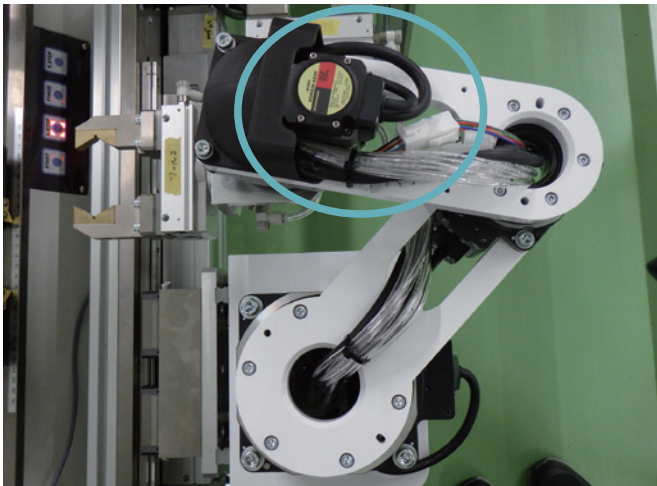

Less Arm Bulk

- Reduced burden from lighter weight
- Shorter takt time
- Useful for cable wiring

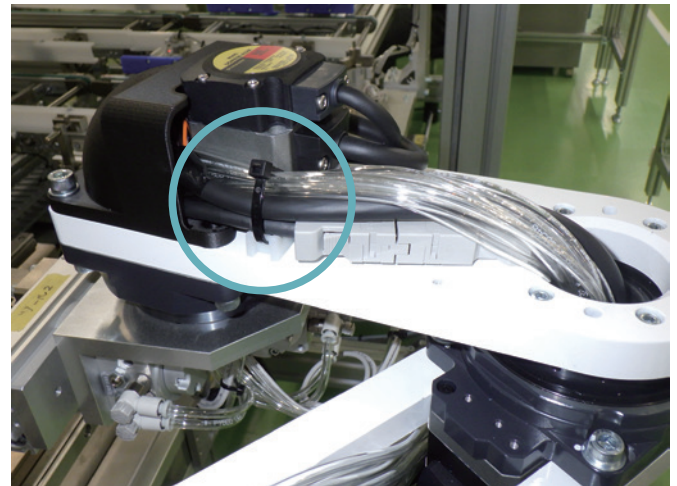

Additional Tapped Holes for Securing Zip Ties

- Secure cables that tend to bulge out

Motor Selection

| We Can Support You with the Motor Selection

Information Needed to Make a Selection Request

- The width (W), depth (D), height (H) and weight of each arm
- The distance between the shafts of each motor
- The weight of the end effector
- The weight of the loads

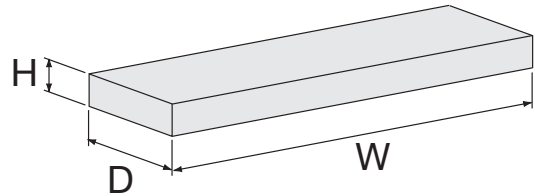

Reach out to your nearest Oriental Motor sales office.
We will assist you in selecting the right drive components.

| For Customers Who Want to Make the Choices Themselves

Items to be Considered

- The weight and center of gravity of each part
- The weight of the end effector
- Calculation of the inertia*

*Must be calculated with the maximum load.

For a horizontal articulated robot, the arm is fully extended.

Items to be Confirmed

- Is the permissible torque and permissible load inertia of each axis satisfied?
- Is the amount of displacement from the load inertia within tolerance?

STEP 3

Robot Assembly

Preparation of Parts

Robot Body

- Arm
- Motors/Actuators

Controller

- Robot Controller
- Driver

Connection Cables

Robot Body



Controller



Stored together in one case

Robot Deployment Expenses (List Price): approx. 10,400.00 €

Robot Controller



MRC01 2,240.00€

2,240.00 €

Driver



AZD-KR2D × 4
369.00€ × 4 = 1,476.00€

1,476.00 €

Motors/Actuators



Axis 1: **DGM130R-AZAK** 1,901.00€
Axes 2 & 3: **DGM85R-AZAK** × 2
1,682.00€ × 2 =
3,364.00€
Z-Axis: **EACM6D20AZMK** 970.00€

6,235.00 €

Power Supply Cable/Connection Cables



Power Supply Cable
RS-485 Communication Cable
Connection Cable
Flexible Connection Cable
The number of each needed

Total: approx. 425.00 €

**Designed & Prepared
by Customer**

**Each Arm: around 150.00 €
Three Arms: approx. 500.00 €**



End Effector

Assembly Procedure

When assembling, we recommend starting from the base and installing in sequence toward the end effector.

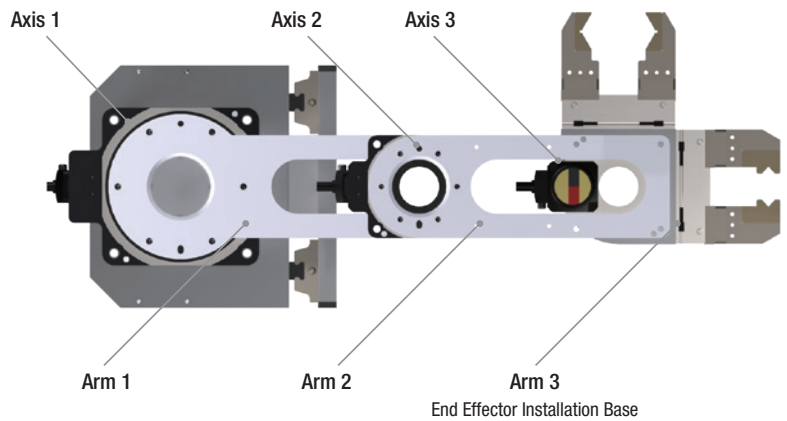

- 1** Secure axis 1 to the workbench
- 2**
- 3**
- 4**
- 5**
- 6** End effector installation
- 7** Installation on Z-axis stage

2 to 6 are tightened with screws after establishing accuracy with positioning pins

SCARA robot pick and place application example designed with AZ Series family products. ►



STEP 4 Setup

MRC01/MRC Studio

- Connect **MRC01** to the robot and launch **MRC Studio**
- Follow the on-screen instructions to “Select an item” or “Enter arm length”

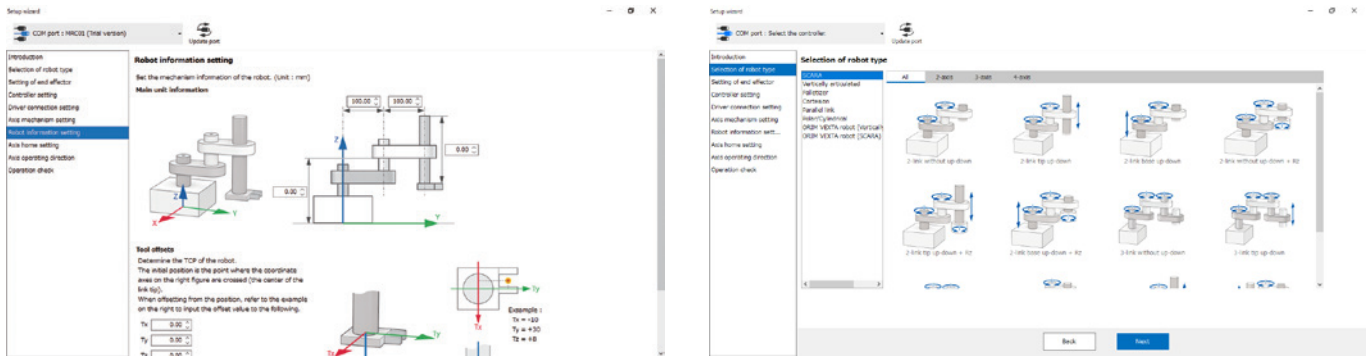

Easy setup following the guide
Intuitive operation following the illustrations

Operation Check

Unit Test

Confirm each movement to be achieved.

- Can loads be gripped?
- Can it reach the transportation position?
- Can it raise and lower?

Integration Test

Combine each movement and confirm that there are no problems with the sequence of movements.

System Test

Connect to the PLC and confirm that the equipment operates without any problems.

Movements Required

- 1 Load gripping
- 2 Carrying in and out
- 3 Removal/attachment by vertical movement

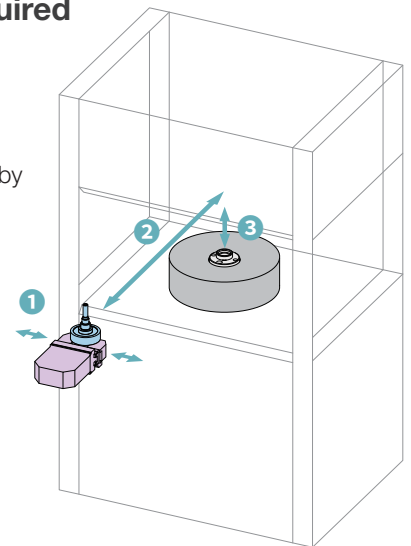

4

The Features of MRC01

The arithmetic processing, operation program creation, and commands necessary for robot control can be accomplished with a single unit

Various knowledge about "Networks", "Ladder programs", and "Kinematics operations" is needed to run custom-built robots. By utilizing the robot controller **MRC01**, custom-built robots can be implemented even without robot control experience.



Enter items using special software

● Coordinates

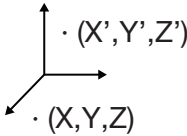

● Speed



● Trajectory

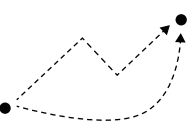

Arithmetic Processing



MRC01

Command & Control

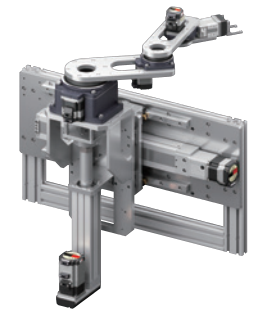

Custom-Built Robot

Simple Programming

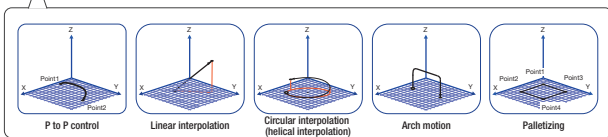
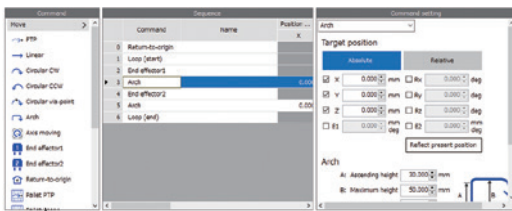

- Select the action needed from a wide variety of commands
- No ladder program knowledge required
- Signal input standby and signal output can also be set using **MRC01**

Compatible with Multiple Robot Types

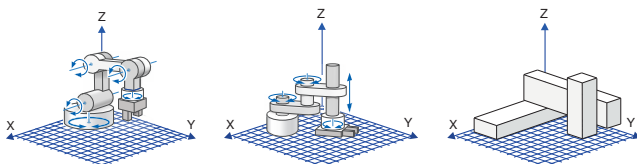

- Select the robot type best suited to the task at hand

Scan this for details about the special software **MRC Studio** (free) ▶



Linking with Host Device Possible

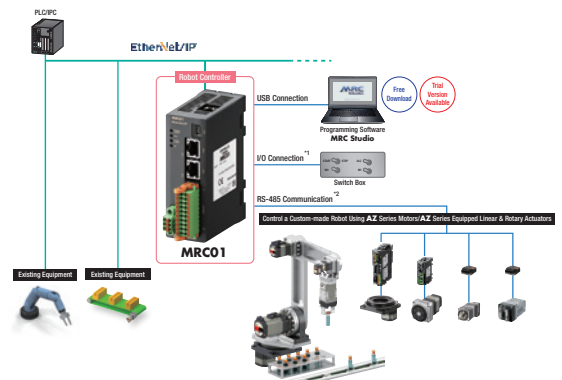

- Operation commands to the robot can be sent directly via EtherNet/IP
- Direct I/O operation without the use of a PLC is possible

Synchronous Control of Various Movements



- Connect and control products equipped with the **AZ** Series
- Linear motion, rotation, and end effectors are controlled with a single unit

Orientalmotor



contact@orientalmotor.de
www.orientalmotor.eu

