

Orientalmotor

Hollow Rotary Actuators
DGI Series

*α*STEP AZ Series Equipped
Servo Motor AZX Series Equipped



These integrated hollow rotary table and motor products allow for the direct installation of large-inertia disks and arms. This can save time and costs associated with designing the mechanism, sourcing necessary parts, assembly, and adjustment.

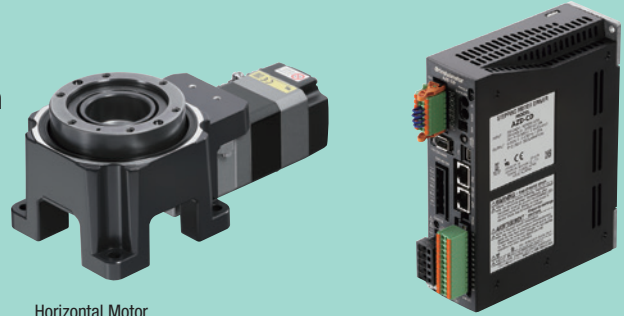

Horizontal Motor Mounting Pedestal

Hollow Rotary Actuators **DGI Series**

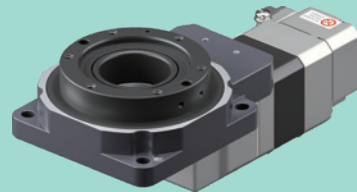

NEW Horizontal Motor Mounting



Vertical Motor Mounting

Parts Procurement,
Mechanism Designing,
Assembly, and
Adjustment:

**Reduced
Hassle**

Hollow Output Table
Max. Diameter of Hollow
Section:

100 mm

Max. Permissible
Torque

50 Nm

Max. Permissible
Axial Load

4000 N

Repetitive Positioning
Accuracy

**±15 arcsec
(±0.004°)**

2 Product Lines Can be Equipped with the Integrated **DGI Series** Motor and Table: The **AZ Series** and the **AZX Series**

Equipped **αSTEP AZ Series** (Page 9)

- Built-In Battery-Free Absolute Encoder
- Max. Permissible Torque: 50 Nm
- Max. Speed: 1800 deg/s
- Wide Variety of Product Lines
- Compatible with Various FA Networks



Ether**CAT**

CC-Link **IE** **Field Basic**

Ether**Net/IP**

Modbus (RTU)

PROFI
NET

Modbus (TDP/IP)

● Refer to pages 4 to 5 for product lines and specifications of each series.

● A Wide Variety of Applications

Load Inertia
Changing Applications

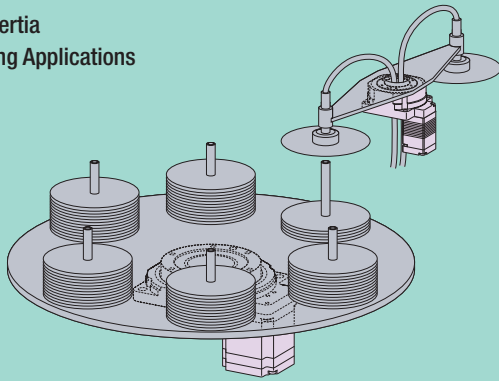

Moment Load
Applications

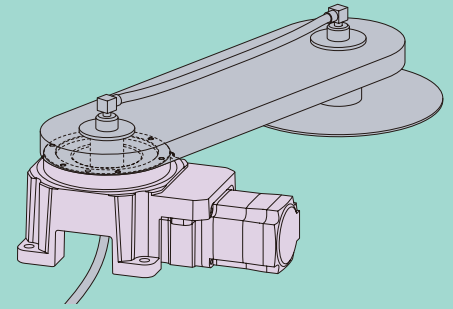

High Accuracy
Positioning Applications

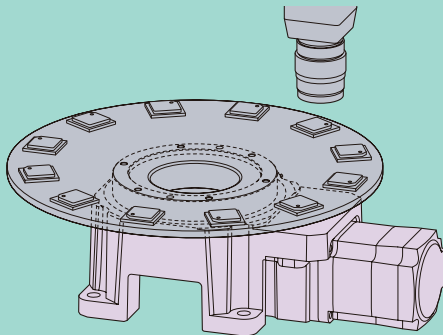

Hollow Hole-Mediated,
High Precision Positioning
Applications

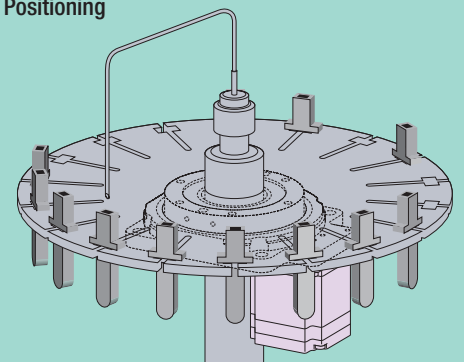

→ For Higher Speed and Higher Torque Demands

Equipped Servo Motor **AZX** Series (Page 16)

- Built-In Battery-Free Absolute Sensor
- Instantaneous Max. Torque: 50 Nm
- Max. Speed: 1833 deg/s
- Network-Compatible Drivers
- The Basic Operations are the Same as the **AZ** Series

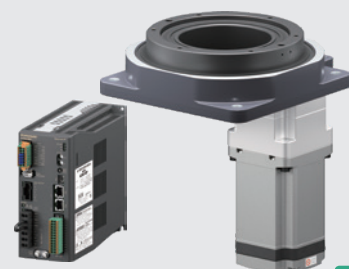



EtherCAT  EtherNet/IP  PROFIBUS 

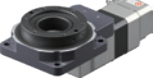

Product Line

*α*STEP AZ Series Equipped

AC Power Input (Cross Roller Bearing)

Motor Mounting Direction	Frame Size [mm]	Electromagnetic Brake	Diameter of Hollow Section [mm]	Gear Ratio	Permissible Torque [Nm]	Max. Speed [deg/s]	Permissible Moment [Nm]	Permissible Axial Load [N]	Lost Motion [arcmin]	Backlash [arcmin]	Angular Transmission Accuracy [arcmin]	Repetitive Positioning Accuracy [arcsec]	
Vertical 	85	Yes	∅33	18	4.5	1200	10	500	2	0	4	±15	
	130		12		50		2000	3					
	200		50		660	100	4000	2					
NEW Horizontal 	85	Yes	∅33	36	9	600	10	500	-	3	3		±30
	130		24		50		2000	3					
Horizontal (Pedestal) 	85	Yes	∅33	12	3	1800	10	500	-	6	6		
				18	4.5	1200							
				36	9	600							
	130		18	12	1200	50	2000						
			36	24	600								

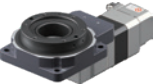





DC Power Input (Cross Roller Bearing)

Motor Mounting Direction	Frame Size [mm]	Electromagnetic Brake	Diameter of Hollow Section [mm]	Gear Ratio	Permissible Torque [Nm]	Max. Speed [deg/s]	Permissible Moment [Nm]	Permissible Axial Load [N]	Lost Motion [arcmin]	Backlash [arcmin]	Angular Transmission Accuracy [arcmin]	Repetitive Positioning Accuracy [arcsec]	
Vertical 	NEW 60	No	∅20	18	0.9	2000	7	350	3	0	10	±15	
	85	Yes	∅33		4.5	1200	10	500			2		4
	130		∅62		12	900	50	2000	3				
NEW Horizontal 	60	No	∅20	30	1.3	1200	7	350	-	10	10		±30
	85		36	∅33	9	600	10	500		3	3		
	130			∅62	24	450	50	2000					
Horizontal (Pedestal) 	85	No	∅33	12	3	1800	10	500	-	6	6	±30	
				18	4.5	1200							
				36	9	600							
	130		18	12	900	50	2000						
			36	24	450								

DC Power Input (Deep-Groove Ball Bearing)

Motor Mounting Direction	Frame Size [mm]	Electromagnetic Brake	Diameter of Hollow Section [mm]	Gear Ratio	Permissible Torque [Nm]	Max. Speed [deg/s]	Permissible Moment [Nm]	Permissible Axial Load [N]	Lost Motion [arcmin]	Backlash [arcmin]	Angular Transmission Accuracy [arcmin]	Repetitive Positioning Accuracy [arcsec]
Vertical 	60	No	Ø28	18	0.9	1200	2	100	2	0	4	±15

AC : Single-Phase 100-120 VAC, Single-Phase/Three-Phase 200-240 VAC Input **DC** : 24/48 VDC Input

Driver Type						
Network-Compatible Drivers  EtherCAT, EtherNet/IP, PROFINET, MECHATROLINK, SSCNET III/H AC DC	Built-in Controller  FLEX Modbus (RTU) AC DC	Pulse Input with RS-485 Communication  AC DC	Pulse Input  AC DC	Network-Compatible Multi-Axis Driver*  EtherCAT, MECHATROLINK, SSCNET III/H DC	miniDriver*  EtherCAT, EtherNet/IP, PROFINET, Modbus (TCP, UDP), CC-Link IE Field Basic, Modbus (RTU) Pulse Input with RS-485 Communication DC	

*Please refer to the Oriental Motor website for product details.

Servo Motor **AZX** Series Equipped

AC: Single-Phase/Three-Phase 200-240 VAC Input

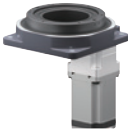
Actuator													
Motor Mounting Direction	Frame Size [mm]	Electromagnetic Brake	Diameter of Hollow Section [mm]	Gear Ratio	Permissible Torque [Nm]	Max. Instantaneous Torque [Nm]	Max. Speed [deg/s]	Permissible Moment [Nm]	Permissible Axial Load [N]	Lost Motion [arcmin]	Backlash [arcmin]	Angular Transmission Accuracy [arcmin]	Repetitive Positioning Accuracy [arcsec]
Vertical 	200	Yes	Ø100	18	19	50	1833	100	4000	3	0	-	±15
		No											

AC : Single-Phase/Three-Phase 200-240 VAC Input

Driver Type
Network-Compatible Drivers EtherCAT, EtherNet/IP, PROFINET, MECHATROLINK  AC

Features of Hollow Rotary Actuators

The **DGII** Series is a line of integrated products that combines a hollow rotary table and **αSTEP AZ** Series stepper motor.

The actuator has an internal speed reduction structure, making high power driving possible.

Features

By using a cross-roller bearing* for the hollow output table, it achieves both high power and high rigidity.

● The figure below shows structure for a vertically mounted motor. The Structure of Hollow Output Table is the Same for Horizontally Mounted Motors.

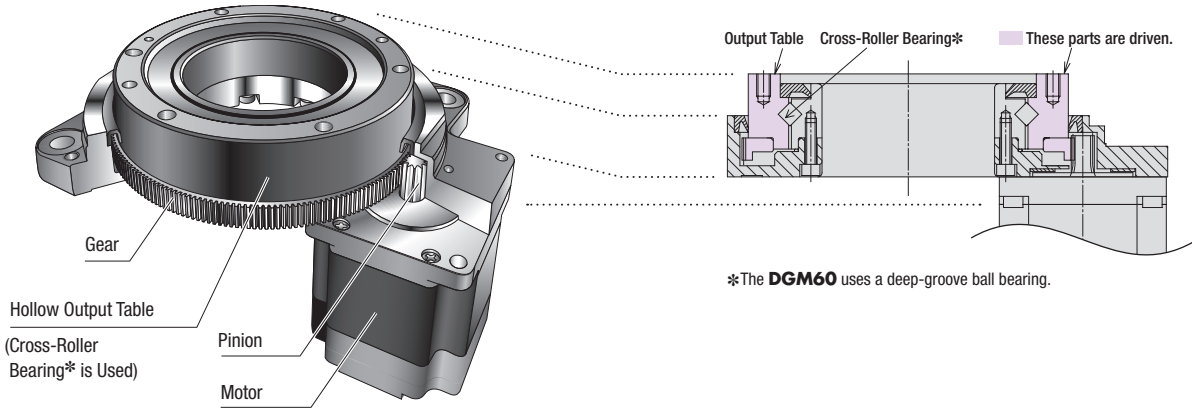

Simplified Design

Equipment tables and arms can be installed directly on the output table. Compared to mechanical components such as a belt and pulley, this saves the hassle and cost of designing the mechanism, arranging for necessary parts, adjusting the belt tension, etc.

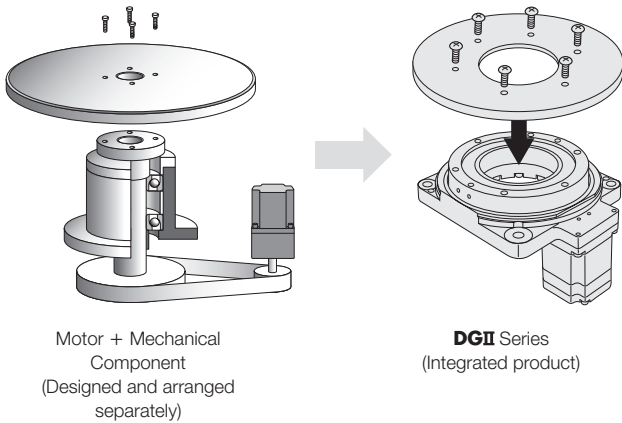

High-precision Positioning

High-precision positioning is achieved by a combination of motor and rotary table mechanism.

Motor Direction	Backlash	Repetitive Positioning Accuracy
Vertical	non-backlash	±15 arcsec (±0.004°)
Horizontal	3 - 10 arcmin	±15 arcsec (±0.004°)
Horizontal (Foot Mounting)	6 arcmin	± 30 arcsec (±0.008°)

Note Accuracy is at constant load and constant temperature (room temperature).

Large-Diameter, Hollow Output Table Makes Simple Wiring and Piping Possible

The large diameter hollow hole (through-hole) helps reduce the complexity of wiring and piping, thus simplifying equipment design.

● Filling Equipment with Piped-in Liquid

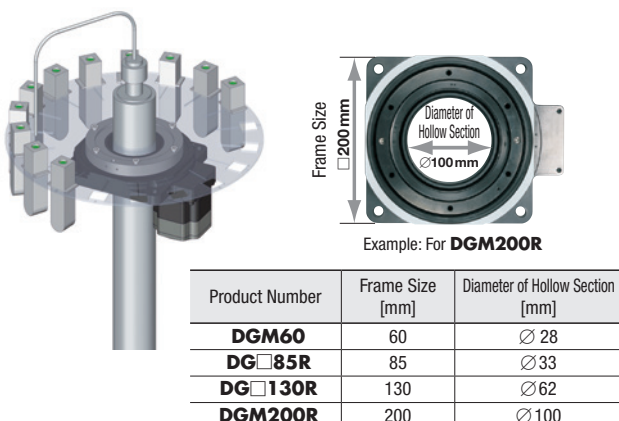

Select the cable pull-out direction to suit the application (only with AZ Series mounting).

The direction of the motor cable pull-out can be selected to suit the application.*1

Motor Direction	Cable pull-out direction/connector direction			
	Upward	Downward	Right Side	Left Side
Vertical	×	○*2	○	○
Horizontal	○	○	○	○*3
Horizontal (Pedestal)	×	×	○	○*4

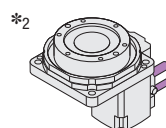

Motor Vertical
Cable Downwards

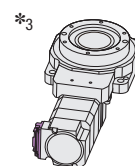

Motor Horizontal
Cable Left Side

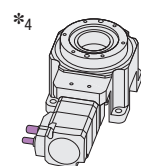

Motor Horizontal (Pedestal)
Cable Left Side

*1 May not be available depending on mounting angle dimensions. Please check the outline drawing.

Specific Use for Specific Space

In addition to the conventional type in which the rotary table axis is assembled parallel to the motor axis (motor vertical mounting), a product line in which the rotary table axis is assembled perpendicularly to the motor axis (motor horizontal mounting) is now available. Select the type that best suits the equipment's installation space.
(Example: For standard type with 85 mm frame size)

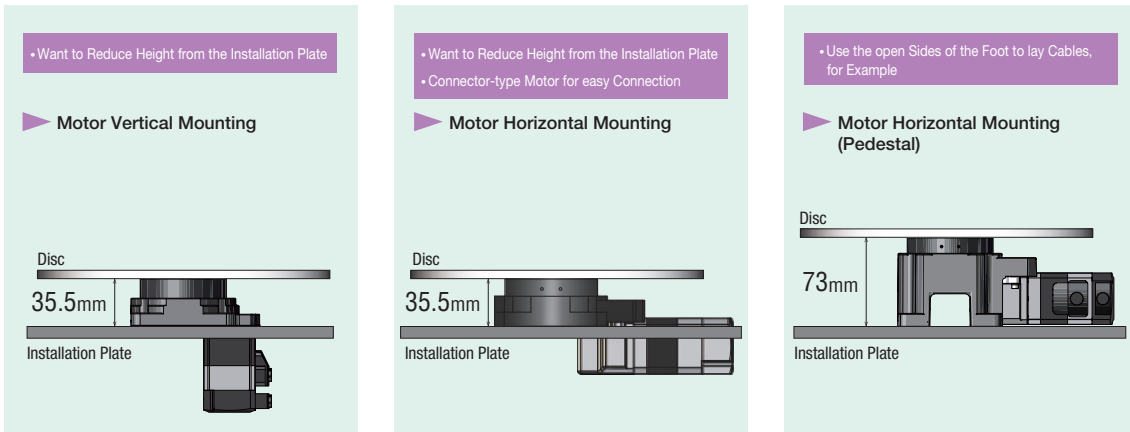

Advantages of Horizontally Mounted Motors

- The installation plate can be omitted because it does not need a relief hole for the motor.
- Pipes and cables can be routed between the legs under the table.

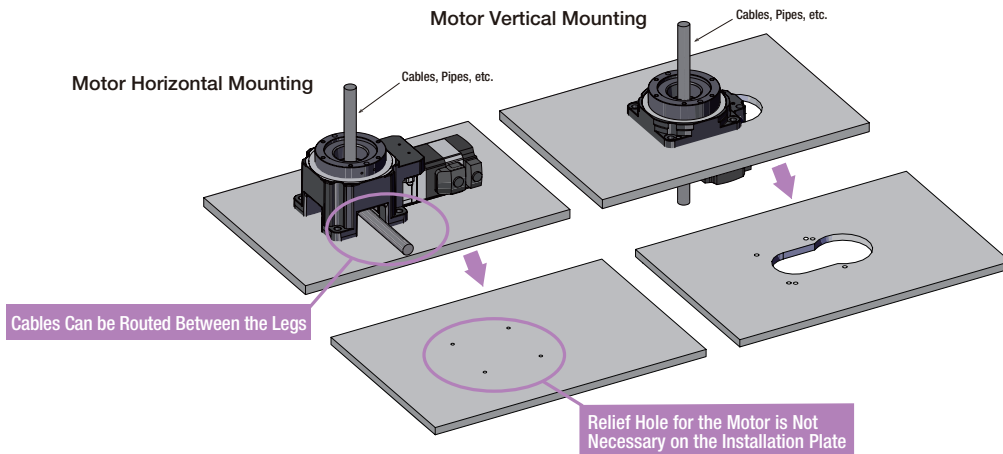

Wider Specification Range through Addition of Gear Ratios (For Horizontally Mounted Motor Only)

Actuators with horizontally mounted motors now come with 3 types of gear ratios: 12, 18 and 36. Select the gear ratio depending on the required speed and required torque.

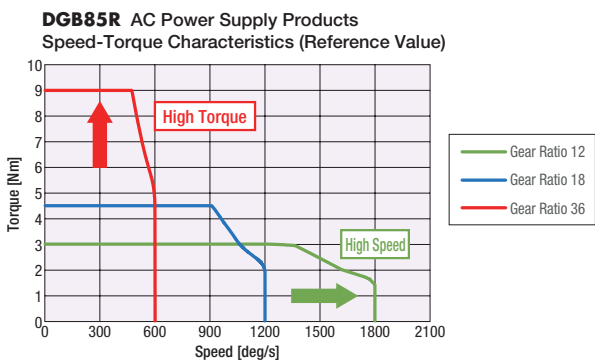

High Load and High Rigidity

A cross-roller bearing is used for the bearing on the hollow output table, providing high load and high rigidity. (Except for **DGM60**)

- Max. Permissible Axial Load: 4000 N
- Max. Permissible Moment: 100 Nm

● High Load

Example: Driving with 6 loads on a table

Load Mass: 91 kg

Table 31 kg (Diameter 500 mm, thickness 20 mm, iron)
Load 10 kg × 6 pieces

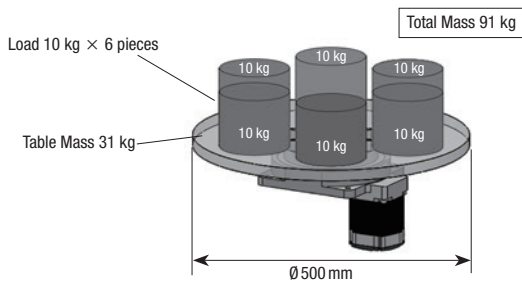

[Axial Load]

$$(31 \text{ kg} + 10 \text{ kg} \times 6 \text{ pieces}) \times \text{gm/s}^2 \approx 893 \text{ N}$$

The axial load for a total mass of 91 kg is 893 N.

The permissible axial load of **DGM200R** is 4000 N, which is within the permissible value.

High Load Driving is Possible

<Operation Example>

Actuator Product Name : **DGM200R-AZAC**

Driver Product Name : **AZD-CD**

Power Supply Input : 200 VAC

Overhung Distance : 160 mm

Installation Direction : Horizontal

● High Rigidity

Example: Driving with a load placed 160 mm away from the table center.

Load Mass: 41 kg

Table 31 kg (Diameter 500 mm, thickness 20 mm, iron)
Load 10 kg × 1 pieces

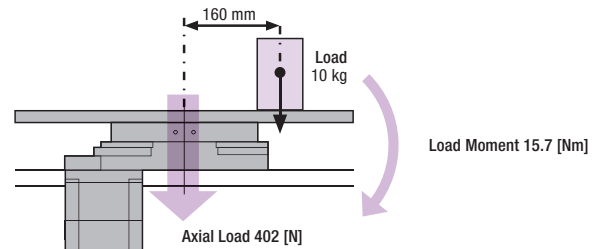

[Load Moment]

$$10 \text{ kg} \times \text{gm/s}^2 \times 0.16 \text{ m} \approx 15.7 \text{ Nm}$$

When a 10 kg load is placed 160 mm from the center of the table, the load moment is 15.7 Nm.

The permissible moment of **DGM200R** is 100 Nm, which is within the permissible value.

[Axial Load]

$$(31 \text{ kg} + 10 \text{ kg}) \times \text{gm/s}^2 \approx 402 \text{ N}$$

The axial load for a total mass of 41 kg is 402 N.

The permissible axial load of **DGM200R** is 4000 N, which is within the permissible value.

This Series Can be Driven Even When a Large Load is Placed Away from the Center of Rotary Actuator Table

■ Relationship Between Displacement and the Load Moment Positioned 200 mm from the Table Center

The received permissible moment increases as the product number increases, and the displacement caused by the load moment decreases.

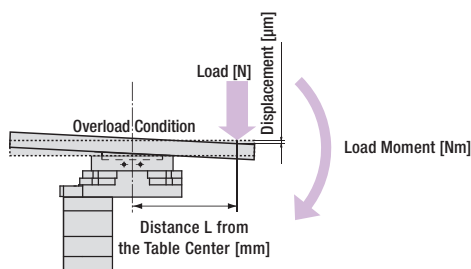

Displacement at L = 200 mm from the Table Center

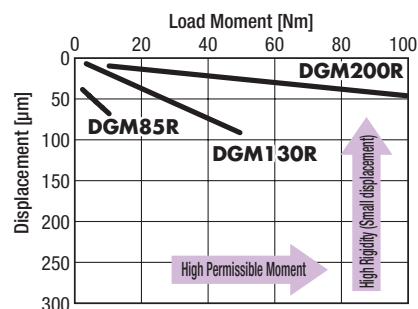

α STEP-Specific High Performance and High Reliability

α STEP is a stepper motor-based series of motors with a unique hybrid control system that combines the advantages of both open loop and closed loop control. The motor positions are constantly monitored and control is switched between 2 types depending on the situation.

Quick Positioning through Agile Responsiveness

Similar to stepper motors, short-distance positioning can be performed in a short amount of time. Since it is a compact yet high-torque motor that operates synchronously with pulse command, it offers excellent acceleration performance and response.

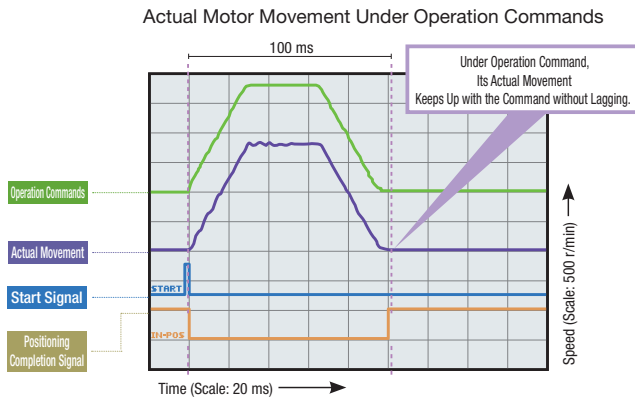

<Operation Example>

- Actuator Product Name : **DGM200R-AZAC**
- Driver Product Name : **AZD-CD**
- Power Supply Input : 200 VAC
- Load Mass : 91 kg
 - : Table 31 kg (Diameter 500 mm, thickness 20 mm, iron)
 - : Load 10 kg \times 6 pieces
- Installation Direction : Horizontal
- Traveling Amount : 60°

Total inertia of table and load = $26330 \times 10^{-4} \text{ kg}\cdot\text{m}^2$

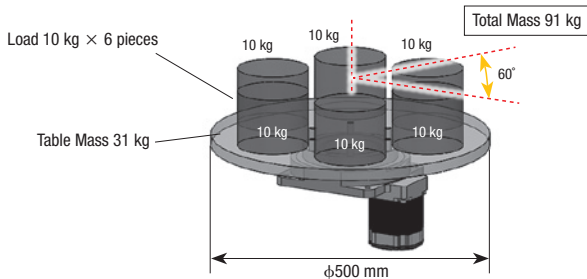

● Quick Positioning

With **DGM200R**, 60° rotation can be driven in 0.59 s with a total mass of 91 kg.

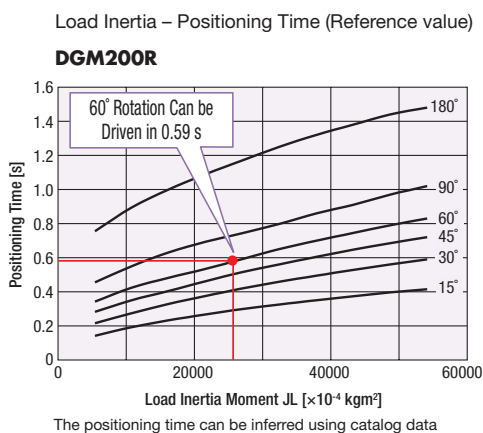

Quick positioning is possible even with large loads



α STEP AZ Series

Built-in Battery-Free Absolute Sensor

Continues Operation Even with Sudden Load Fluctuation and Sudden Acceleration

In normal conditions, it operates synchronously with pulse commands under open loop control, and because of its compact size and high torque generation, it has excellent acceleration performance and responsiveness. In an overload condition, it switches immediately to closed loop control to correct the position.

Low Vibration Even at Low Speed

Thanks to the microstep drive system and smooth drive function*, which come standard, resolution can be improved without mechanical elements such as a speed reduction mechanism. As a result, speed fluctuation is minimal even at low speeds, leading to improved stability.

*What is Smooth Drive Function?

The smooth drive function automatically microsteps based on the same traveling amount and traveling speed used in the full step mode, without changing the pulse input settings.

Alarm Signal Output in Case of Abnormality

If a continuous overload is applied, an alarm signal is output. Also, when the positioning is completed, a signal is output. This provides high reliability.

Tuning-Free

Since it is normally operated under open loop control, the movement that has been configured in setting is secured without tuning even when there is load fluctuation.

Holding the Stop Position without Hunting

Thanks to the open loop control under normal condition, it does not cause a phenomenon known as hunting in which the shaft moves slightly when it is stopped. Since it can hold the stop position securely, it is ideal for applications where absence of vibration upon stopping is required.

Energy Savings, Low Heat Generation

High-efficiency motors reduce heat generation and save energy.

α STEP AZ Series Equipped Absolute System-Mediated Simple Home Setting and Return-to-Home

Oriental Motor has developed a compact mechanical multi-turn absolute sensor <ABZO Sensor> (patented). This can help improve productivity and reduce costs.



Home Sensor is Not Necessary

Because it is an absolute system, there is no need for a home sensor.

Reduced Costs

This can lower the sensor costs and wiring costs, which can lower the system system costs.

Simple Wiring

Wiring is simplified, and the degree of freedom for equipment design is increased.

Not Affected by External Sensor Malfunctions

There are no concerns for malfunction, failure or disconnection of external sensors.

Improved Return-to-Home Accuracy

Home position accuracy is increased because the return-to-home operation is performed regardless of any variations in home sensor sensitivity.

*If no limit sensor is installed, movements that exceed the limit values can be avoided through the use of the limits in the driver software.

Simple Home Setting

The home position can be easily set by pressing a switch on the driver's surface, which is saved by the Absolute Sensor. In addition, home setting is possible with the support software (**MEXE02**) or by using an external input signal.

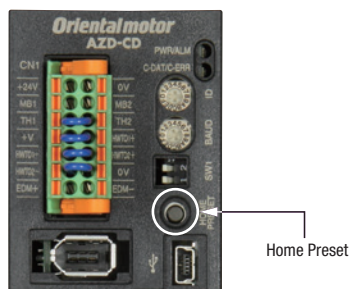

High-Speed Return-to-Home

Because return-to-home is possible without using a home sensor, return-to-home can be performed at high speed without taking the sensor sensitivity into account, allowing for a shortened machine cycle.

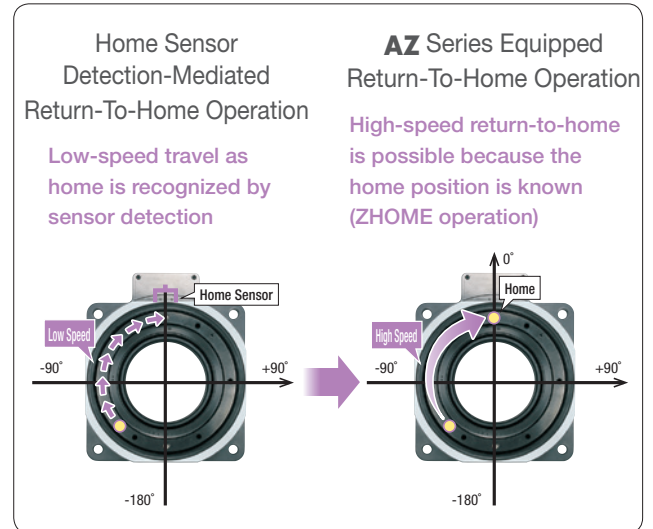

Return-to-Home is Not Necessary

Even if the power shuts down during a positioning operation, the positioning information is stored. With the built-in controller type, you can restart the positioning operation without performing return-to-home after an emergency stop on the production line or a blackout.

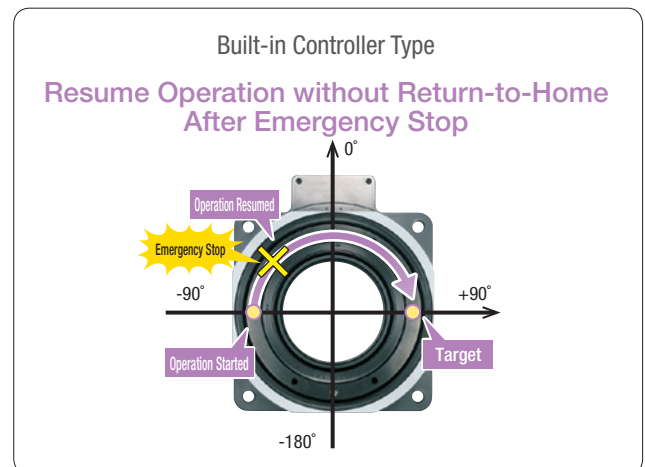

Mechanical-Type Sensor Means No Batteries

Battery-Free

No battery is required because it is a mechanical-type sensor. Because positioning information is managed mechanically by the Absolute Sensor, the positioning information can be preserved, even if the power turns off, or if the cable between the motor and the driver is disconnected.

Reduced Maintenance

Because there is no battery that needs replacing, maintenance time and costs can be reduced.

Unlimited Driver Installation Possibilities

Because there is no need to secure space for battery replacement, there are no restrictions on the installation location of the driver, improving the flexibility and freedom of the layout design of the control cabinet.



Safe for Overseas Shipping

Batteries will self-discharge, so care must be taken when the equipment requires a long transportation time, such as when being sent overseas. The Absolute Sensor does not require a battery, so there is no limit as to how long the positioning information is maintained. In addition, there is no need to worry about various safety regulations, which must be taken into consideration when shipping a battery overseas.

Position Holding Even when the Cable between the Motor and Driver is Detached

Positioning information is stored within the Absolute Sensor.

Convenient Functions Unique to AZ Series Equipped Models

Convenient Operation and Setting

Using the functions of AZ Series allows for coordinate control on the output table of a hollow rotary actuator, the following operations can be performed.

Shorter Takt Time with Shortcut Operation

In this operating mode, the system is driven in the rotation direction that has the shortest distance towards the set target position. It can shorten the equipment's takt time.

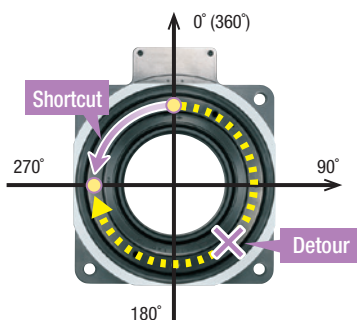

Example:
When traveling from 0° position to 270°, it automatically selects the shorted counter-clockwise rotation direction for driving.

Easy Control with Prohibited Access Range Setting

If there are any obstacles on the equipment, it is possible to set the range in which movement is prohibited on the output table.

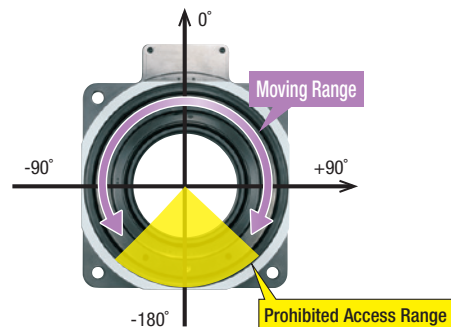

Reduced Equipment Startup Time

The parameters required for operating the hollow rotary actuator have been set as factory setting. This contributes to reduced startup time of the equipment.

- Home
- Resolution setting (0.01°/step)
- Rotation direction setting for the output table
- Round setting ±180°

● Each initial setting can be changed.

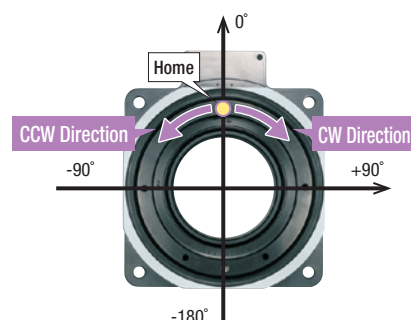

Easy Setting and Easy Operation with Support Software

By using the support software, data setting, actual drive, and confirmation via each monitor function can be performed easily on a computer.

Support Software MEXE02

The support software can be downloaded from the Oriental Motor website.



● Operating Data/Parameter Settings

You can easily set the operating data and parameters on a computer. Since the setting data can be stored, the same setting can be applied simply by forwarding the saved data when you replace a driver, etc.

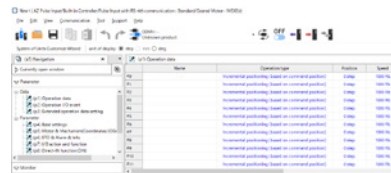

● Teaching and Remote Operation

Positioning adjustment can be performed on support software or manually, and it can be imported into the driver as operation command information. This can be used for equipment start-up.

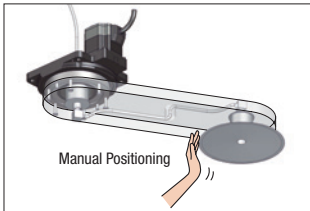

● Multi-monitoring enables remote operation and teaching while monitoring.

Various Monitoring Functions

● I/O Monitoring

The status of the I/O wired to the driver can be checked on a computer. This can be used for post-wiring I/O checks or I/O checks during operation.

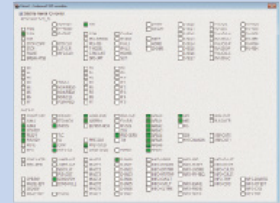

● Waveform Monitoring

The operating status of the motor (such as command speed and motor load factor) can be checked from an oscilloscope-like image. This can be used for equipment start-up and adjustment.

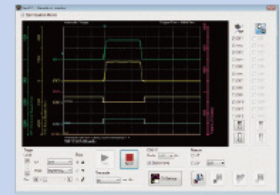

● Alarm Monitoring

When an abnormality occurs, the details of the abnormality and the solution can be checked.



Sequence Function Simplifies Programming (Not available in some models)

AZ Series is equipped with a variety of sequence functions, such as a timer setting between operations and linked operation, conditional branching and loop counting. Sequence programming of the host system can be simplified.

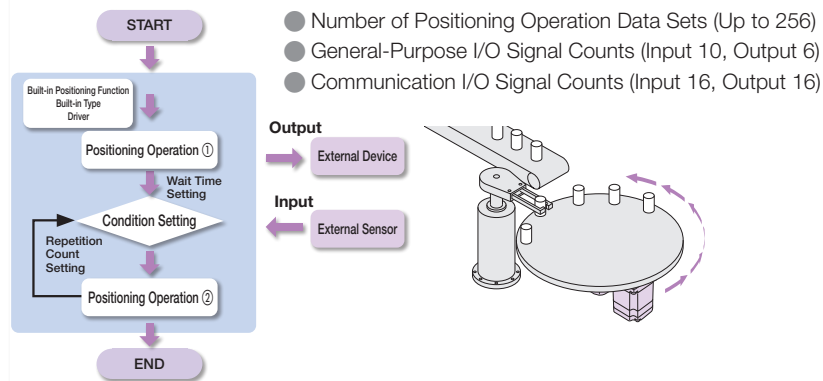

Application & Usage Examples

Applications that Require High Rigidity

- Applications in which a Load Moment is Applied

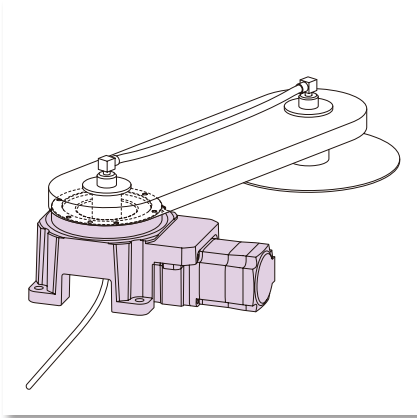

Applications that Require High Performance Motors

- High Positioning Accuracy Applications (Image Inspection Equipment)

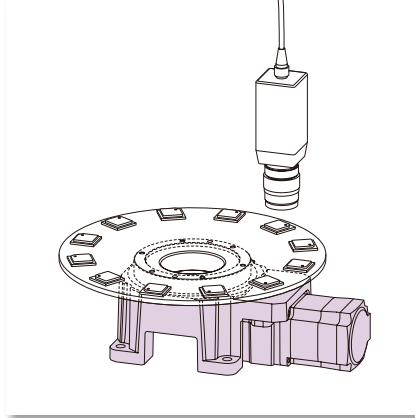

- Applications with Load Inertia Fluctuations (Disk Manufacturing Equipment)

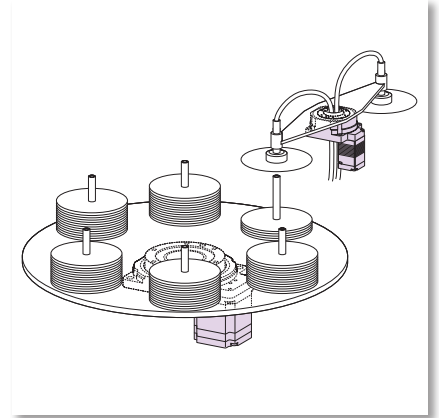

Installation Direction Examples

The **DGI** Series can not only be installed horizontally, but can also be ceiling mounted or wall mounted.

Note

A small amount of grease will occasionally seep out of the hollow rotary actuator. If a grease leak would cause a contamination issue near the machine, either perform routine inspections, or install protective equipment such as an oil sump.

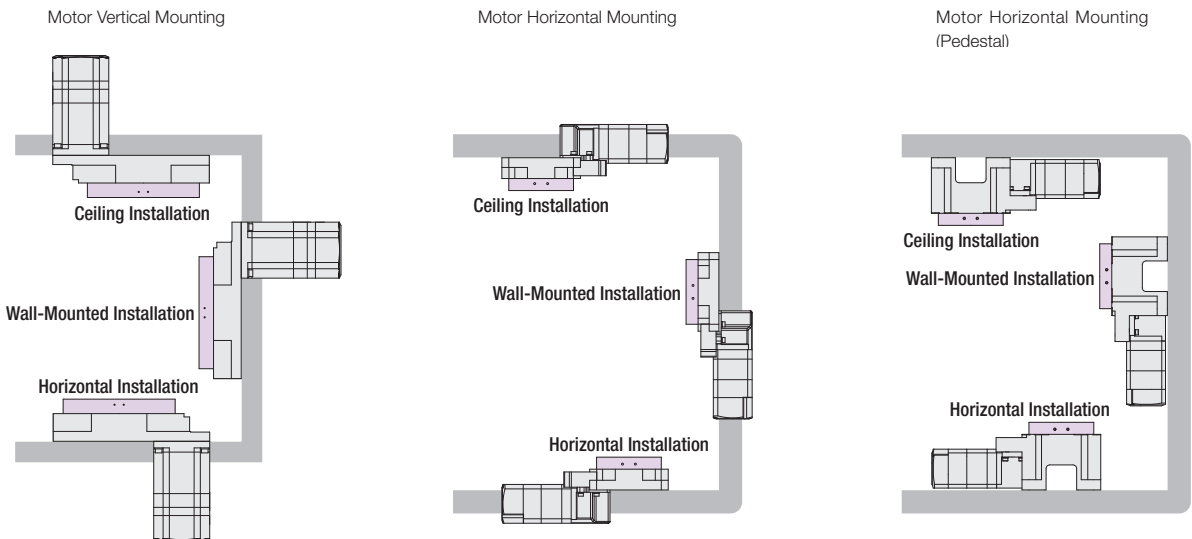

Servo Motors

AZX Series Equipped

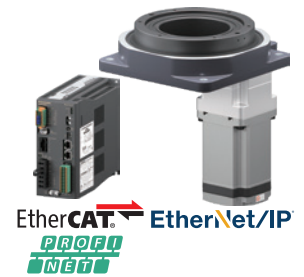

Achieves High Torque in High Speed

The **AZX** Series-equipped systems achieves high torque in high speed. It is suitable for positioning applications involving large traveling amount and continuous operation applications.

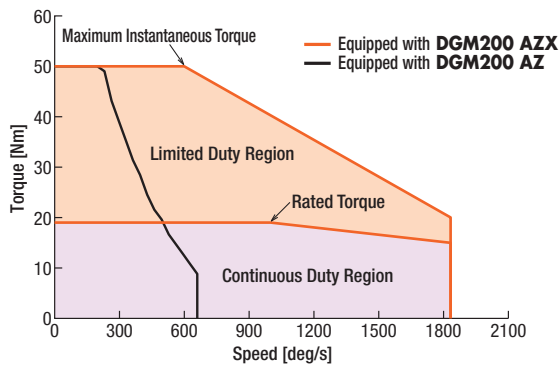

- This is a comparison of the speed-torque characteristics of the **DGII** Series equipped with **AZX** Series and **AZ** Series. The system equipped with **AZX** Series offers superior torque in the high speed range while the system equipped **AZ** Series is better in the low speed range.

Cable Outlet Direction Can be Changed

Since motors in systems equipped with the **AZX** Series are bonded through couplings, the motor unit can be disassembled. Changing the motor's direction allows for the cable outlet direction to be changed, which increases the freedom during the designing stage.

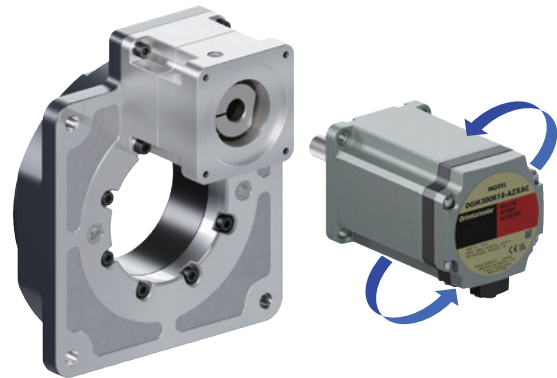

Servo Motor Equipped with Battery-Free Absolute Encoder

The driving servo motor **AZX** Series features the same battery-free mechanical absolute encoder (ABZO sensor) as the **αSTEP AZ** Series. This is a servo motor specialized for both positioning and continuous operation.

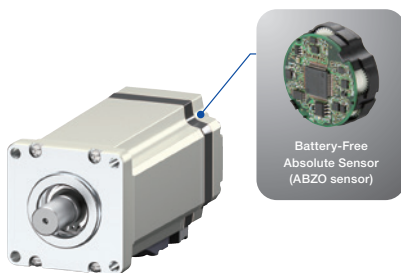

- Mechanical-Type Sensor**
Holds positioning information even when powered off
- Multi-Turn Absolute Sensor**
Absolute position detection is possible with ± 900 rotations (1800 rotations) of the motor shaft from the reference home position

For details on the **AZX** Series, check the Oriental Motor website.

The Same Basic Operations as the AZ Series

The basic operations of the **AZX** Series are the same as the **AZ** Series. This reduces operational hassle when they are used together within the same equipment.

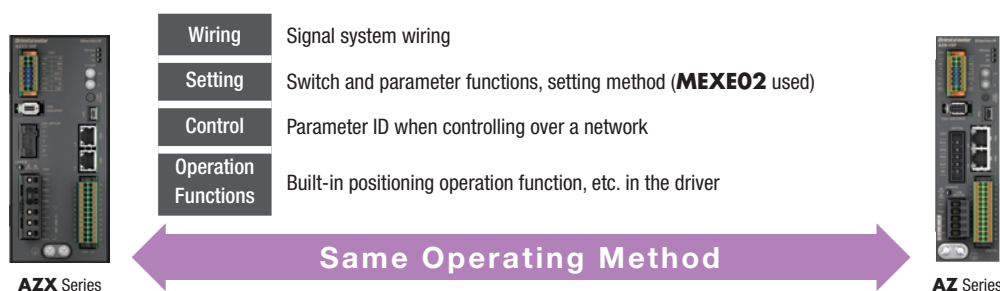

Hollow Rotary Encoder

DGII Series

Motorless Type, Frame Size 130 mm, 200 mm

This is a standalone actuator (motorless type) from the **DGII** Series. The actuator structure remains the same as the **DGII** Series and is designed for use with servo motors from various manufacturers, connected via the actuator's coupling. It is ideal for large-inertia drive applications.

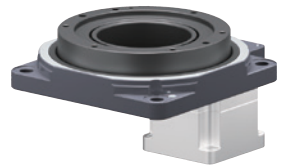

Exclusively for use with servo motors from various companies

Large diameter, high strength hollow output table (same as existing **DGII** Series).

The large-diameter hollow output table is constructed with cross-roller bearings for high rigidity and high torque.

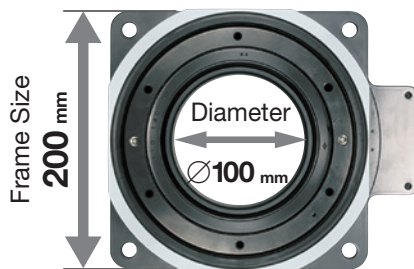

Example: **DGN200**

The permissible axial load is **4000 N**

The permissible torque is **30 Nm**

The instantaneous maximum torque is **50 Nm**

Designed exclusively for use with servo motors from various manufacturers.

It is compatible with servo motors from various manufacturers, and they can be connected using the tables coupling. Please see page 2 for manufacturers compatible with the combination.

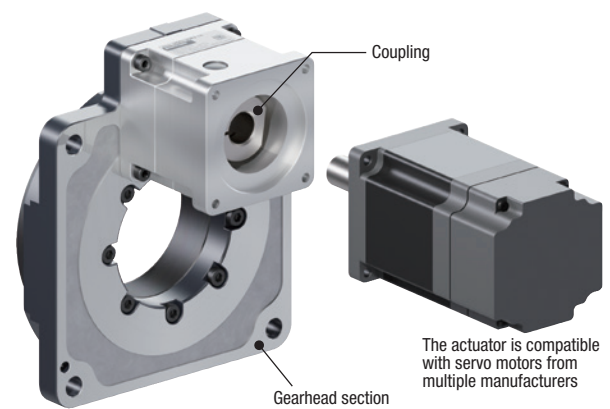

Note: This product cannot be combined with our range of motors.

Wiring and piping are simplified using the tables large-diameter hollow hole.

The large diameter through holes can be used for wiring and piping reducing complex routing, simplifying the equipment design.

- Filling equipment with piped liquid

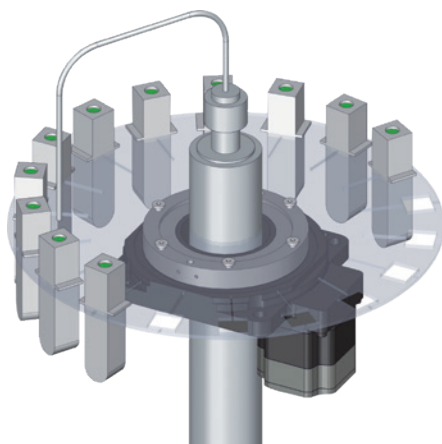

Space-saving in the vertical direction.

The height of the hollow output table is reduced to 37 mm, minimising the vertical height.

- Example: **DGN130**

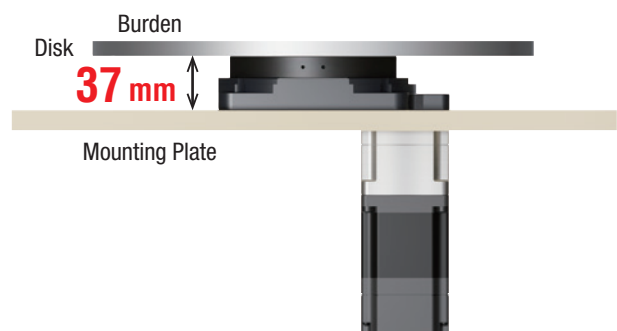

Oriental motor

More about Oriental Motor



Company



Products



Applications



Exhibitions



Support

Follow us!

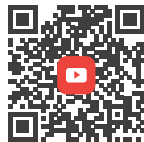

YouTube



LinkedIn



Newsletter

Oriental Motor (Europa) GmbH

European Headquarters
Schiesstraße 44
40549 Düsseldorf, Germany
Tel: +49 211 520 670 0
contact@orientalmotor.de
www.orientalmotor.eu

These products are manufactured at plants certified with the international standards **ISO 9001** (for quality assurance) and **ISO 14001** for systems of environmental management). Specifications are subject to change without notice. This catalogue was published in August 2025. Printed in Germany.

© Copyright Oriental Motor (Europa) GmbH 2025
UK/082025/VERS01