

Orientalmotor

Brushless Motor

BMU Series

Easy Speed Control with Spin and Push



30 W Full Size

Easy Speed Control with Spin and Push

A settings dial designed for easy speed control.

Once the motor and the driver are connected, all you do for this simple wiring is turn on the switch.

The new brushless motor NexBL is a compact, high-power, and high-efficiency motor.

For the **BMU** Series that focuses on user-friendly features and affordable prices, we also provide various gearheads, including hypoid right-angle hollow shaft gearheads.*

Wider applications.

*Some gearheads support H1 food-grade lubricant



- ① Spin and push. Easy speed control.
- ② Easy wiring. Quick start.
- ③ Opening the panel reveals extensive functions.
- ④ New Brushless Motor NexBL.

Brushless Motor **BMU** Series

BMU Series



List of Product Line

Gearhead Product Line	Parallel Shaft Gearhead GFV Gear Round Shaft Type		Parallel Shaft Gearhead JV Gear		Foot Mount Gearhead JB Gear	Right-Angle Shaft Hollow Hypoid Gearhead JH Gear	Hollow Shaft Flat Gearhead FR Gear
	H1 Grade Lubricant Compatible* Dust-Resistant, Watertight Specification*						
Degree of Protection	IP66	IP66	IP67	IP66	IP44	IP66	IP65
Motor Output Power							
30 W	●	●					●
60 W	●	●				●	●
120 W	●	●				●	●
200 W	●		●	●	●	●	●
300 W	●		●	●	●	●	●
400 W	●		●	●	●	●	●

*Only available for parallel shaft gearhead **GFV** gearhead

Main Features of BMU Series

- Easy speed control with “Spin and Push” of the setting dial.
- Easy wiring by connecting the motor and the driver and turning on the switch.
- Employs new compact, high output, highly efficient brushless motors.
- Lineup cable and connector types.
- Delivers the highest level of speed control at reasonable prices.

● Connection Method

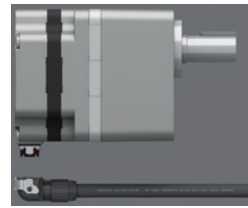

Connection Cables / Flexible Connection Cables (Sold separately)

Connector Type Motor (Degree of protection IP66 specification)

Features

Spin and Push. Easy Speed Control.



Turn the dial, and set the speed to your desired speed.



Turning the dial slowly changes the speed by 1 r/min.



Pushing the dial sets the speed.



The dial operation can be locked.

Easy Wiring. Quick Start.

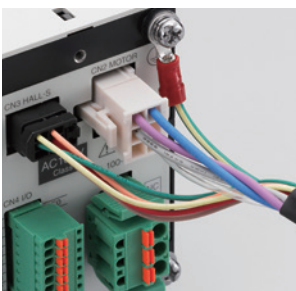

The motor and driver can be easily connected.



The power and I/O connectors are of the screwless type.



With only one switch, the motor can be started immediately.



The rotation direction of the motor can be changed with easy operation.

Maximum Speed of 4000 r/min Speed Ratio 1:50* (2.5 times of the conventional ratio)

BMU Series has a maximum speed of 4000 r/min*. Speed ratio of 1:50 (80 - 4000 r/min*) is realized. Speed regulation has been greatly improved from $\pm 0.5\%$ to $\pm 0.2\%$. With the highest standards of speed control, we respond to our customers' demands.

*Depends on the gearhead.

●BMU Series 120W

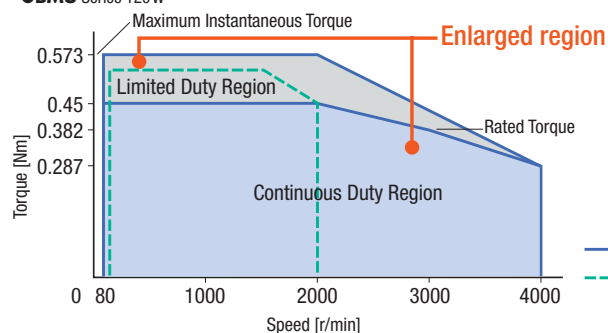

If You Open the Front Panel on the Driver, You Can Set Up Various Functions.

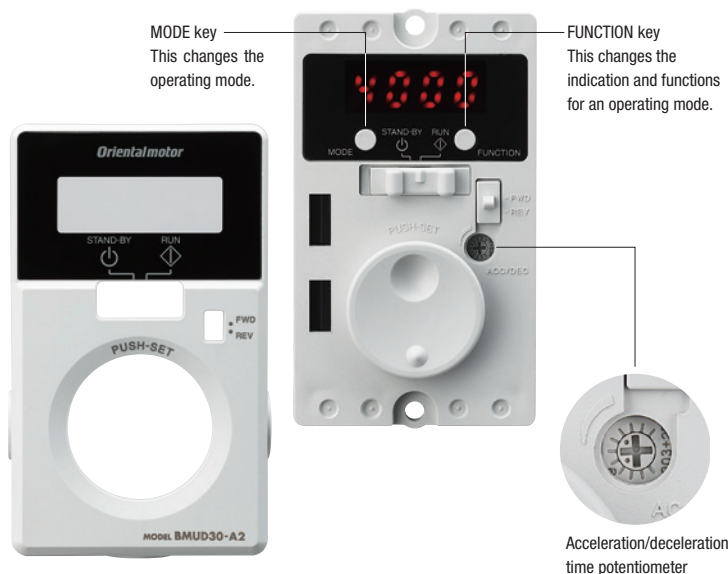

(Typical functions that can be set while the front panel is opened)

- Motor Start/Stop*
 - Adjustment of operating speed*
 - Setting the operating speed*
 - Selecting the rotation direction*
 - Changing the indication
 - Operating speed indication when the speed reduction/speed increasing ratio is set
 - Setting the acceleration/deceleration time
 - Dial operation lock
 - Speed setting for the 4-speed operation
 - Speed limits setting
 - Validating the external operating signals
 - External input/output signal allocation
 - Setting the overload alarm detection time, except during axial lock
 - Easy holding function for output shaft
- *Setting is possible even if the front panel is attached.

Speed indication

Displays the motor rotational speed by 1 r/min. Additionally, with the "gear ratio" parameter of a conveyor, the display shows the conveyor transfer speed in m/s directly.



Load factor indication

With the rated torque of the motor at 100%, the load factor can be expressed in percentage (40 - 200%). The load condition during the start-up, as well as the load condition due to the aging deterioration of the equipment can be confirmed.



Indication at a load factor of 50%

Protective function

Various protective functions such as overload protective function and overvoltage protective function are equipped. When a protection is triggered, it shows the alarm code on the display and outputs an alarm signal.



4-speed setting

Operation in 4 speeds is possible by setting the data to operating data No.0, No.1, No.2, or No.3, and switching the input of the M0 and M1 terminals.

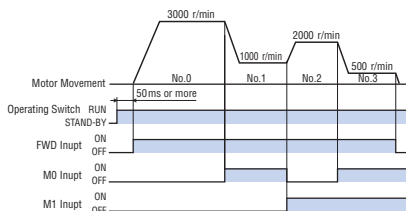

- In 4 speed drive, switching of the rotation direction from external input signals cannot be performed. (For 30, 60, 120W)

Sets the acceleration/ deceleration time

The acceleration time and deceleration time can be digitally set, in addition to adjusting them with an acceleration/deceleration time potentiometer.

- Setting range:
0.0 - 15.0 sec (Initial value: 0.5 sec)

For the digital setting, the acceleration time and deceleration time are each set independently. This allows you to finely adjust the speeds to mitigate shocks on conveyed products at startups and stops and freely set them according to the desired tact time.

Output shaft is held when stopped

When the motor is stopped, the load can be electrically held.

(Holding force is up to 50% of the rated torque.)

Note

If the electrical power supply to the driver is turned OFF, the holding force dissipates. This cannot be used to prevent a fall during a power outage.

Other functions

● Lock the dial operation

This prevents the undesired changes in the speed and the changes or deletion of data with the operation of the dial.

● You can set to "Front Panel Operation Invalid"

When operating using external signals, the front panel switch operation can be set to "Invalid".

Locking Lever-Type Connector for Direct Connection (Connector Type)

The locking lever connector for small motors enables direct connection between the motor and the driver.

Easy Connection

Connecting the cable is easy due to the lock lever that does not require screws.

● Attachment Method



Cable Outlet Direction Can be Selected

Choose from 3 types of cable outlet directions of the motor to suit the equipment.

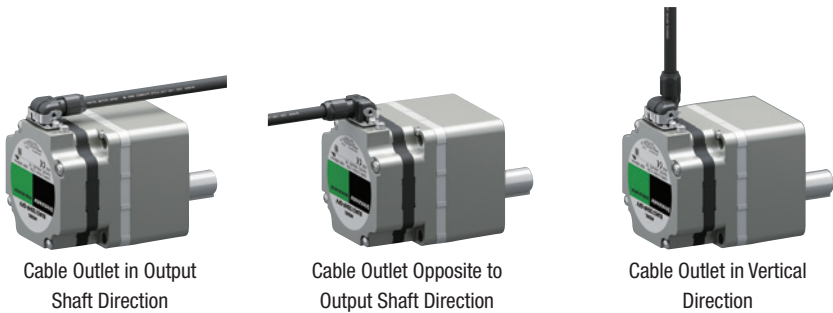

Motor-Driver Direct Connection

Without an extension cable, a connection of up to 10 m is possible. No extension cable is required. The wiring process is simplified by using one cable, instead of power lines, signal lines, and ground wires.

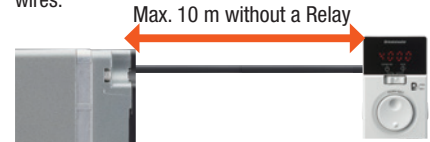

Flexible Cables are Also Available

Use the flexible connection cable in applications where the cable is bent and flexed repeatedly.

IP67 Watertight, Dust-Resistant Motor Features

It has a watertight, dust-resistant structure that can withstand environments prone to water splashes and dusts, and it can also be washed easily with water.

Washable, Including the Motor

Water and Dust Resistant

IP67 Structure, Including the Connector Units

Improved Corrosion Resistance

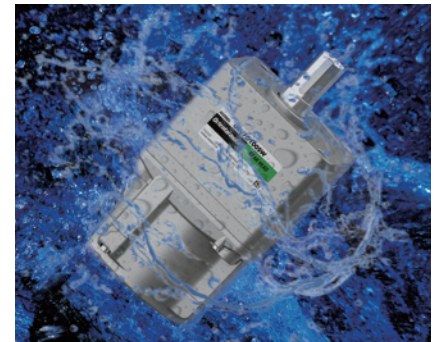

Superior Protective Structure

Sealing parts (O-rings) are used in joints between parts to prevent water from entering the motor. It is suitable for uses that require washing of the motor with water.

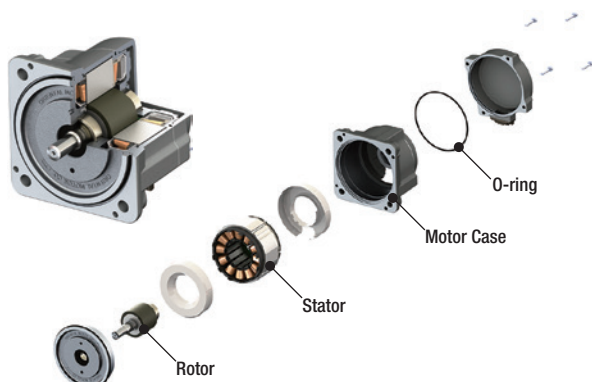

The internal gasket and O-ring improve the watertight performance of the connector structure. It is IP67-rated, including the connector units.

● Connector Structure

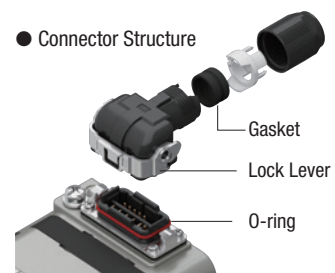

Washable IP67 Rating

It can operate in locations prone to dust and water.

Because it can be washed with water, it can stay installed on the equipment without a protective cover.

Washable while still attached to the equipment

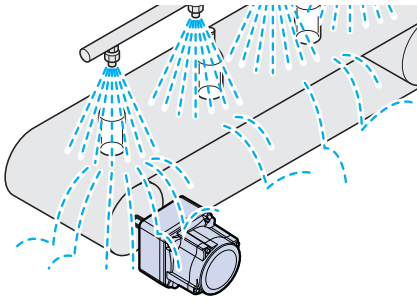

Suitable for applications where there is dust

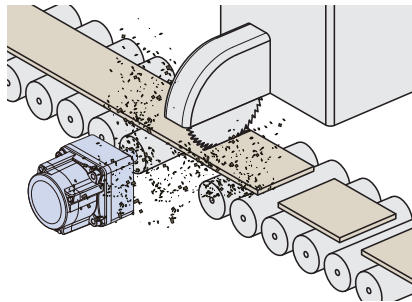

IP67

- Usable after immersion in water under specified conditions
- Completely dust-proof structure

<Watertight Test Conditions>

Immersion to a depth of 1 m for 30 minutes

*Do not use it under water or where the water pressure is high.

“Water-Washing Resistant Test” for Prolonged Service Life

Oriental Motor’s Proprietary Assessment*1

The sealing parts (O-rings) may become deteriorated over the course of motor operation, resulting in compromised watertight performance.

The sealing parts are therefore put through “water-washing resistant test”, which are our proprietary assessment standards designed to address the issue of deterioration over time, to ensure that water does not enter the motor.

Oriental Motor’s Proprietary “Water-Washing Resistant Tests”*2

- ① Thermal Shock Test: 5 years worth of heat deterioration is applied to the sealing parts (O-rings)
- ② Vibration Test: Vibration is applied to the motor
- ③ Water Spray Test: Water is sprayed at a pressure of 100 kPa

*1 These tests are performed under Oriental Motor’s in-house conditions and methods, and they are not intended to guarantee fail-free operation.

*2 For details on the test conditions, please see the Oriental Motor website. → <https://www.orientalmotor.co.jp/ja>

Improved Corrosion Resistance

A special rust-resistant coating is applied and stainless steel is used for the output shafts and screws. The mounting surface is also coated so that it resists rusting even when it is assembled onto a stainless steel equipment.

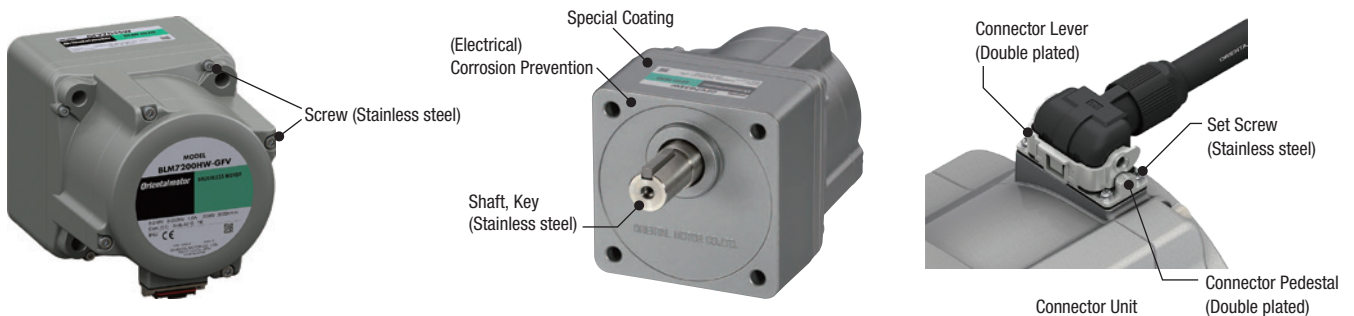

Sloped Motor Shape

The motor has a sloped design for easier water flow when it is being washed. It is designed so that water will flow easily regardless of the motor’s installation direction.



Suitable for Clean Environment

The fact that it is a high-efficiency motor means that there is no cooling fan. Because of this, the motor will not stir and kick up dust from the outside.

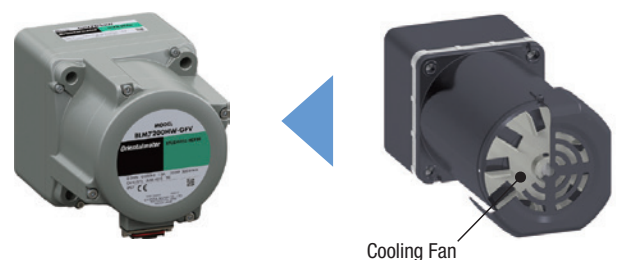

Right-Angle Shaft Gearhead

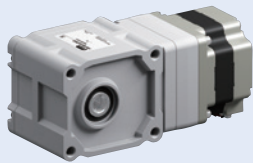

Hypoid Right-Angle Hollow Shaft **JH** Gear

Space Saving

Placing the motor at right angles saves space.

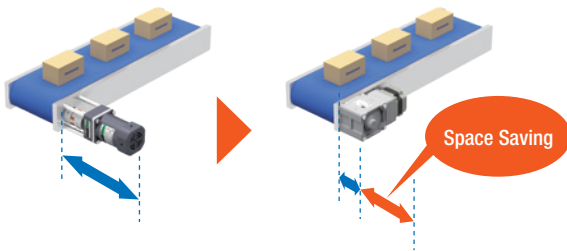

Cost Saving

Reduced couplings, belts, pulleys, and other parts contribute to reduced parts costs and assembling steps.

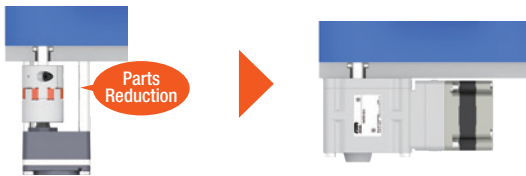

Hollow Shaft Flat Gearhead

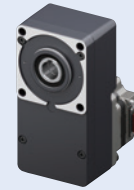

Hollow Shaft Flat Gearhead **FR** Gear

Space Saving

Direct connection to the drive shaft is possible without using coupling parts, which enables equipment space saving.

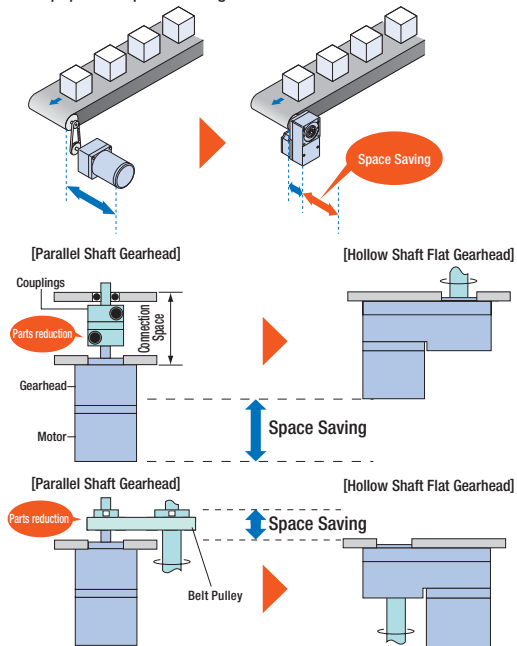

Unsaturated Permissible Torque

The permissible torque is not saturated even at a high gear ratio. Therefore, the benefit of the motor torque can be maximized.

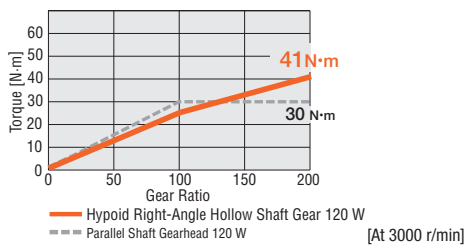

Permissible Torque with No Saturation

Permissible torque will not become saturated even at high gear ratios. This is useful for maximizing the motor torque.

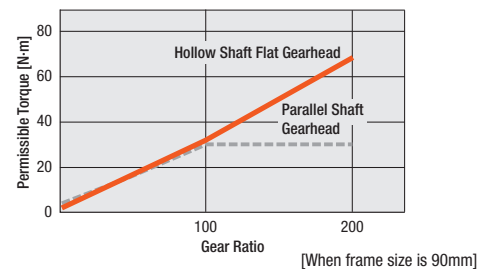

High Strength

Comparison with parallel shaft gearhead

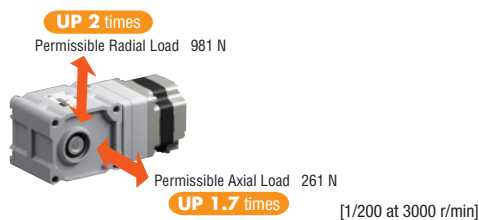

Higher Permissible Torque, Longer Service Life

With improved gear case durability and larger gear and bearing diameters, the permissible torque is higher and the service life is longer. It has reached a rated life of 10000 hours.



Selectable High-Strength, High-Gear Ratio Gearheads to Suit Your Needs

In addition to the conventional parallel shaft gearhead **GFV** gearhead, Oriental Motor offers specialized gearheads to meet your needs, including high-gear ratio, high-strength, and space-saving gearheads. Maximum permissible torque and permissible load of the output shaft have also been improved significantly. They are also compatible with equipment in various environments.

Gearhead Rated Life of 10000 Hours

H1 food-grade lubricant compatible and watertight, dust-resistant models also available



Parallel Shaft Gearhead **GFV** Gear

Gear Shape for Extensive High Gear Ratios and Easy Installation



Parallel Shaft Gearhead **JV** Gear

Foot Mount Gearhead **JB** Gear

For Space-Saving Applications and Permissible Torque with No Saturation



Right-Angle Hollow Shaft Hypoid **JH** Gear

Hollow Shaft Flat Gearhead **FR** Gear

H1 Food-Grade Lubricant Compatible (Connector Type, Parallel shaft gearhead **GFV** gear)

H1 food-grade lubricant is used for gear lubrication.

● What is H1 food-grade lubricant?

It is a grease categorized by the NSF as "a lubricant with incidental food contact for use in and around food processing areas" categorized by the NSF.

What is the NSF (NSF International)?

It is an international third-party certifier headquartered in the U.S. which provides global services regarding public health and the environment, including standard development, product certification, audits, education, and risk management.

● The rated life of the gearhead is 5,000 hours

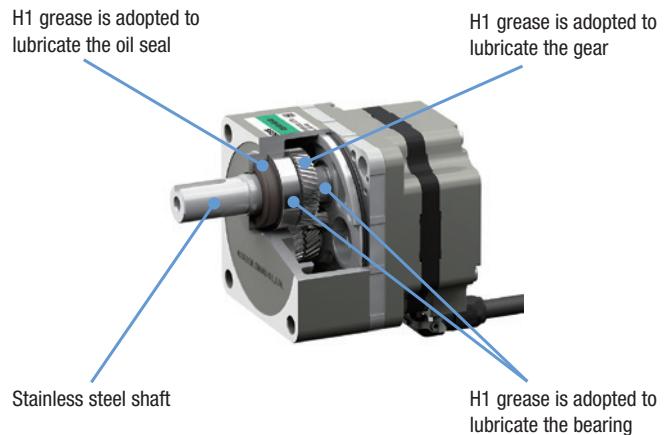

Brushless Motor Features

A brushless motor is a speed control motor that combines a high-efficiency compact motor and a dedicated circuit (driver). This motor leads to conservation of energy and resources, and therefore contributes to carbon neutral initiatives.

A built-in permanent magnet in the motor's rotor unit and its optimal magnetic design makes this a highly efficient motor.

The feedback control with the built-in sensor (hall effect IC) enables accurate speed control in response to commands.

Unlike using inverter control on an AC motor, the low-speed torque is not restricted and a constant rated torque is used from low speed to high speed.

● Motor Structure

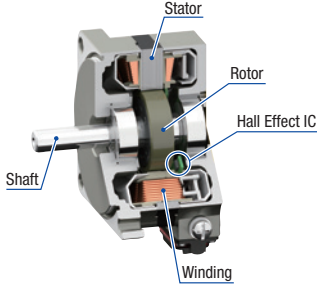

● Motor Control

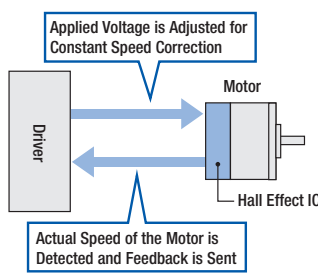

● Wide Speed Range, Constant Torque

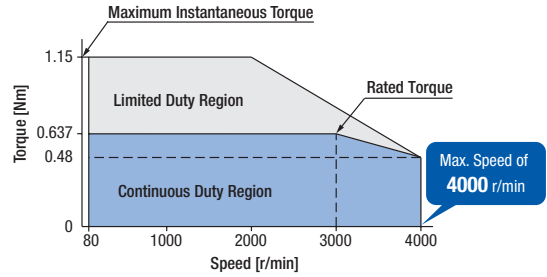

IE4-Equivalent* High-Efficiency, Energy-Saving Motor

A brushless motor is a high-efficiency motor that exceeds the IE4 standards. It is more efficient than applying inverter control on an AC motor (induction motor), and it leads to reduced power consumption and CO₂ emission.

● Energy Saving Effects

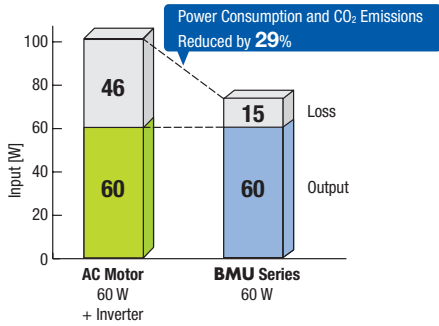

● Efficiency at Various Outputs

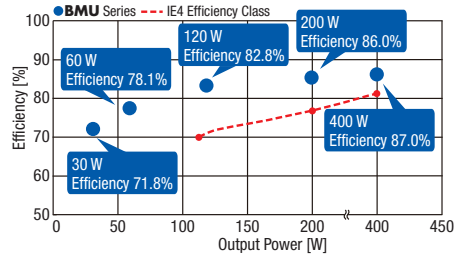

*This is an efficiency class stipulated by the international standards IEC 60034-30-1, and it applies to induction motors of 120 W or higher.

*The IE4 efficiency data is based on rated output power of 4-pole motor. The efficiency data for brushless motor is based on application of rated torque at rated speed.

Thin, Lightweight and High Power

The brushless motors use permanent magnets so that they are thin and lightweight but yet have high power. These contribute to the downsizing of equipment.

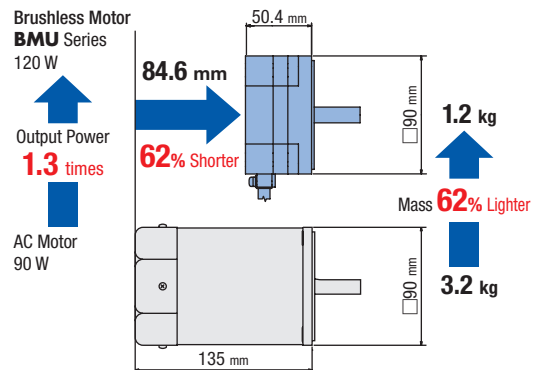

Steady Operation at Preset Speed





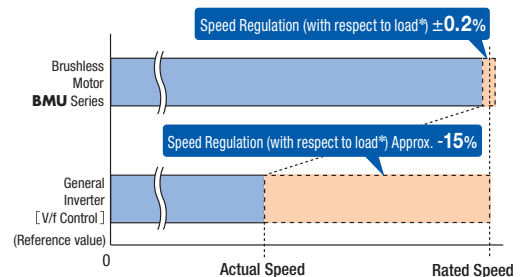

The feedback signal from the motor is monitored constantly and compared against the preset speed to adjust the applied voltage. This means that the motor will operate at the preset speed, from low speed to high speed, even if the load fluctuates.

*Rate of change in speed when a constant load is applied.

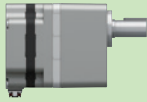



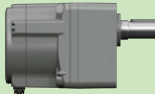

$$\text{Speed regulation} = \frac{\text{Actual speed} - \text{Command speed}}{\text{Rated speed}} \times 100 (\%)$$



Product Line

Type	Motor Type	Connection Cable/Flexible Connection Cable Type		Driver Type
Connector Type			<p>Cable Outlet in Output Shaft Direction</p>  <p>Cable Outlet Opposite to Output Shaft Direction</p> 	 <p>30/60/120 W</p>
Watertight, Dust-Resistant Connector Type	<p>Watertight, Dust-Resistant Motor</p> 	<p>Connection Cable 0.5 - 10 m</p> <p>Flexible Connection Cable 1.0 - 10 m</p>	<p>Cable Outlet in Vertical Direction</p> 	 <p>200/300/400 W</p>

Connector Type

Output Shaft Type/Output Shaft Material		Frame Size [mm]	Rated Output Power [W]	Gear Ratio	Degree of Protection	Rated Voltage [VDC]	
Parallel Shaft Gearhead	GFV Gearhead -Stainless Steel Shaft 	60	30	5 - 200	IP66	Single-Phase 100-120 Single-Phase 200-240 Three-Phase 200-240	
		80	60				
		90	120				
		110	200	5 - 100			
			300	5 - 50			
	GFV Gearhead H1 Food-Grade Lubricant Compatible -Stainless Steel Shaft	60	30	5 - 200		Single-Phase 100-120 Single-Phase 200-240 Three-Phase 200-240	
		80	60				
		90	120				
	JV Gearhead -Stainless Steel Shaft 	*1	200	300, 450		IP66	Single-Phase 100-120 Single-Phase 200-240 Three-Phase 200-240
			300	200 - 450			
400			100 - 450				
Foot Mount Gearhead JB Gearhead -Iron Shaft 	*1	200	5 - 1200	IP44	Single-Phase 100-120 Single-Phase 200-240 Three-Phase 200-240		
		300	5 - 600				
		400					
Right-Angle Hollow Shaft Hypoid Gearhead JH Gearhead -Stainless Steel Shaft 	*1	60	10 - 200	IP66	Single-Phase 100-120 Single-Phase 200-240 Three-Phase 200-240		
		120					
		200	5 - 200				
		300					
		400					
Hollow Shaft Flat Gearhead FR Gearhead -Iron Shaft 	*1	30	5 - 200	IP65	Single-Phase 100-120 Single-Phase 200-240 Three-Phase 200-240		
		60					
		120					
		200	10 - 100				
		300					
		400				5 - 100	
Round Shaft Type*2 -Stainless Steel Shaft 	60	30	-	IP66	Single-Phase 100-120 Single-Phase 200-240 Three-Phase 200-240		
		60					
		120					
	90	200					
		300					
		400					
		400				Single-Phase 200-240 Three-Phase 200-240	

*1 Refer to the dimensions shown on the product information page.

*2 Round shaft type includes a type with shaft flat.

Watertight, Dust-resistant Connector Type

Output Shaft Type/Output Shaft Material		Frame Size [mm]	Rated Output Power [W]	Gear Ratio	Degree of Protection	Rated Voltage [VDC]
Parallel Shaft Gearhead GFV Gearhead -Stainless Steel Shaft 	110	200	5 - 100	IP67	Single-Phase 100-120 Single-Phase 200-240 Three-Phase 200-240	
		300				
		400	5 - 50			Single-Phase 200-240 Three-Phase 200-240

● 2 types of motors, one with mounting screws and one without mounting screws, are available.

Oriental motor

More about Oriental Motor



Company



Products



Applications



Exhibitions



Support

Follow us!

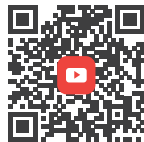

YouTube



LinkedIn



Newsletter

Oriental Motor (Europa) GmbH

European Headquarters
Schiesstraße 44
40549 Düsseldorf, Germany
Tel: +49 211 520 670 0
contact@orientalmotor.de
www.orientalmotor.eu



Available in the
ePLAN data portal.